



NW101 Chest

HEIGHT: 220 cm
 LENGTH: 89 cm
 WIDTH: 70 cm
 IN-GROUND: 40 cm
 WEIGHT: 83 kg
 Free fall height: 75 cm
 ZONE: 11,2 m²



NW102 Back

HEIGHT: 220 cm
 LENGTH: 89 cm
 WIDTH: 73 cm
 IN-GROUND: 40 cm
 WEIGHT: 77 kg
 Free fall height: 62 cm
 ZONE: 11,2 m²



NW103 Sit Up

HEIGHT: 56 cm
 LENGTH: 216 cm
 WIDTH: 39 cm
 IN-GROUND: 25 cm
 WEIGHT: 35 kg
 Free fall height: 56 cm
 ZONE: 17 m²



NW104 Pull Up

HEIGHT: 222 cm
 LENGTH: 113 cm
 WIDTH: 103 cm
 IN-GROUND: 40 cm
 WEIGHT: 125 kg
 Free fall height: 222 cm
 ZONE: 23,7 m²



NW105 Bar

HEIGHT: 103 cm
 LENGTH: 106 cm
 WIDTH: 58 cm
 IN-GROUND: 25 cm
 WEIGHT: 35 kg
 Free fall height: 103 cm
 ZONE: 12,7 m²



NW106 Leg

HEIGHT: 220 cm
 LENGTH: 93 cm
 WIDTH: 61 cm
 IN-GROUND: 40 cm
 WEIGHT: 75 kg
 Free fall height: 60 cm
 ZONE: 11,9 m²



NW107 Dual Pull Up

HEIGHT: 223 cm
 LENGTH: 132 cm
 WIDTH: 103 cm
 IN-GROUND: 40 cm
 WEIGHT: 86 kg
 Free fall height: 137 cm
 ZONE: 15 m²



NW108 Arm Walker

HEIGHT: 198 cm
 LENGTH: 83 cm
 WIDTH: 308 cm
 IN-GROUND: 40 cm
 WEIGHT: 83 kg
 Free fall height: 98 cm
 ZONE: 22 m²



NW110 Multi Ladder

HEIGHT: 93 cm
 LENGTH: 191 cm
 WIDTH: 68 cm
 IN-GROUND: 25 cm
 WEIGHT: 65 kg
 Free fall height: 93 cm
 ZONE: 15,4 m²



NW201 Air Walker

HEIGHT: 127 cm
 LENGTH: 253 cm
 WIDTH: 96 cm
 IN-GROUND: 25 cm
 WEIGHT: 98 kg
 Free fall height: 40 cm
 ZONE: 20 m²



NW202 Cross

HEIGHT: 172 cm
 LENGTH: 220 cm
 WIDTH: 47 cm
 IN-GROUND: 40 cm
 WEIGHT: 93 kg
 Free fall height: 40 cm
 ZONE: 15,7 m²



NW204 Hip

HEIGHT: 123 cm
 LENGTH: 250 cm
 WIDTH: 113 cm
 IN-GROUND: 25 cm
 WEIGHT: 65 kg
 Free fall height: 40 cm
 ZONE: 20,9 m²



NW206 Rider

HEIGHT: 145 cm
 LENGTH: 99 cm
 WIDTH: 56 cm
 IN-GROUND: 25 cm
 WEIGHT: 50 kg
 Free fall height: 70 cm
 ZONE: 12,1 m²



NW207 Triple Jumper

HEIGHT: 70 cm
 LENGTH: 207 cm
 WIDTH: 227 cm
 IN-GROUND: 25 cm
 WEIGHT: 82 kg
 Free fall height: 70 cm
 ZONE: 25,7 m²



NW301 Twister

HEIGHT: 123 cm
 LENGTH: 252 cm
 WIDTH: 162 cm
 IN-GROUND: 25 cm
 WEIGHT: 80 kg
 Free fall height: 77 cm
 ZONE: 22,6 m²



NW303 Balancer

HEIGHT: 38 cm
 LENGTH: 272 cm
 WIDTH: 32 cm
 IN-GROUND: 25 cm
 WEIGHT: 65 kg
 Free fall height: 38 cm
 ZONE: 17,1 m²



NW401 Stretch

HEIGHT: 123 cm
 LENGTH: 250 cm
 WIDTH: 39 cm
 IN-GROUND: 25 cm
 WEIGHT: 39 kg
 Free fall height: 90 cm
 ZONE: 17,2 m²

All dimensions listed are for installed in-ground equipment.



NW502 Ping Pong



NW501B Bench

HEIGHT: 51/78 cm
 LENGTH: 142 cm
 WIDTH: 48 cm
 IN-GROUND: 25 cm
 WEIGHT: 72 kg
 Free fall height: 78 cm
 ZONE: 13,5 m²



NW502 Ping Pong

HEIGHT: 74/91 cm
 LENGTH: 275 cm
 WIDTH: 153 cm
 IN-GROUND: 25 cm
 WEIGHT: 196 kg
 Free fall height: 74 cm
 ZONE: 23,7 m²



NW503 Sign

HEIGHT: 107 cm
 LENGTH: 48 cm
 WIDTH: 83 cm
 IN-GROUND: 25 cm
 WEIGHT: 24 kg
 ZONE: 11,4 m²



NW504 Mini Sign

HEIGHT: 87 cm
 LENGTH: 29 cm
 WIDTH: 30 cm
 IN-GROUND: 25 cm
 WEIGHT: 8 kg
 ZONE: 8,9 m²



NW501B Bench





NWS113 Hand Cycle

HEIGHT: 116 cm
 LENGTH: 92 cm
 WIDTH: 93 cm
 IN-GROUND: 25 cm
 WEIGHT: 40 kg
 Free fall height: 116 cm
 ZONE: 11,6 m²



NWS114 Tai Chi

HEIGHT: 125 cm
 LENGTH: 93 cm
 WIDTH: 50 cm
 IN-GROUND: 25 cm
 WEIGHT: 25 kg
 Free fall height: 94 cm
 ZONE: 11,9 m²



NWC609 Combi 5



COMBI UNITS



NWC603 Combi 1

HEIGHT: 223 cm
 LENGTH: 260 cm
 WIDTH: 108 cm
 IN-GROUND: 30 cm
 WEIGHT: 110 kg
 Free fall height: 116 cm
 ZONE: 20,9 m²



NWC605 Combi 3

HEIGHT: 127 cm
 LENGTH: 253 cm
 WIDTH: 215 cm
 IN-GROUND: 25 cm
 WEIGHT: 150 kg
 Free fall height: 40 cm
 ZONE: 25,6 m²



NWC609 Combi 5

HEIGHT: 220 cm
 LENGTH: 170 cm
 WIDTH: 73 cm
 IN-GROUND: 40 cm
 WEIGHT: 160 kg
 Free fall height: 46 cm
 ZONE: 15,5 m²



NWC607 Calisthenics

HEIGHT: 239 cm
 LENGTH: 335 cm
 WIDTH: 335 cm
 IN-GROUND: 30 cm
 WEIGHT: 505 kg
 Free fall height: 239 cm
 ZONE: 35,5 m²



NWC608 Functional Training

HEIGHT: 239 cm
 LENGTH: 408 cm
 WIDTH: 351 cm
 IN-GROUND: 30 cm
 WEIGHT: 675 kg
 Free fall height: 139 cm
 ZONE: 42,6 m²

Incl. one set of rings and punching bag



NWSW112 Step Blocks



NWSW110 Dual Bar



NWSW116 Boxer



NWSW108 Tire Flip

HEIGHT: 54 cm
 LENGTH: 302 cm
 WIDTH (tire): 121 cm
 IN-GROUND: 25 cm
 WEIGHT (ex tire): 30 kg
 Free fall height: 54 cm
 ZONE: 21,6 m²

Excl. tire



NWSW109 Horizontal Ladder

HEIGHT: 205 cm
 LENGTH: 103 cm
 WIDTH: 377 cm
 IN-GROUND: 40 cm
 WEIGHT: 200 kg
 Free fall height: 205 cm
 ZONE: 36,7 m²



NWSW110 Dual Bar

HEIGHT: 103 cm
 LENGTH: 190 cm
 WIDTH: 57 cm
 IN-GROUND: 25 cm
 WEIGHT: 65 kg
 Free fall height: 103 cm
 ZONE: 15,8 m²



NWSW112 Step Blocks

HEIGHT: 40 cm
 LENGTH: 29 cm
 WIDTH: 152 cm*
 IN-GROUND: 25 cm
 WEIGHT: 75 kg
 Free fall height: 40 cm
 ZONE: 13 m²

*total width (2 pcs)



NWSW114 Triple Pull Up

HEIGHT: 225 cm
 LENGTH: 104 cm
 WIDTH: 292 cm
 IN-GROUND: 40 cm
 WEIGHT: 195 kg
 Free fall height: 121 cm
 ZONE: 21 m²

Incl. rings



NWSW115 Parkour

HEIGHT: 235 cm
 LENGTH: 119 cm
 WIDTH: 119 cm
 IN-GROUND: 25 cm
 WEIGHT: 125 kg
 Free fall height: 232 cm
 ZONE: 20,8 m²



NWSW116 Boxer

HEIGHT: 235 cm
 LENGTH: 120 cm
 WIDTH: 30 cm
 IN-GROUND: 30 cm
 WEIGHT: 60 kg
 ZONE: 11,9 m²



NWSW117 Rope

HEIGHT: 235 cm
 LENGTH: 104 cm
 WIDTH: 8,8 cm
 IN-GROUND: 30 cm
 WEIGHT: 77 kg
 ZONE: 10,4 m²

All dimensions listed are for installed in-ground equipment.



NWC607 Calisthenics



NWC608 Functional Training



NWSW108 Tire Flip



NWSW109 Horizontal Ladder



NWSW117 Rope



Norwell Starter
(minimum 34,5m²)

- 1. NW101 Chest
- 2. NW202 Cross
- 3. NW301 Twister
- 4. NWSW110 Dual Bar



Norwell Standard
(minimum 78m²)

- 1. NW101 Chest
- 2. NW102 Back
- 3. NW103 Sit Up
- 4. NW104 Pull Up
- 5. NW201 Air Walker
- 6. NW202 Cross
- 7. NW206 Rider
- 8. NW301 Twister
- 9. NWSW110 Dual Bar
- 10. NW503 Sign



Norwell Street Workout
(minimum 66 m²)

- 1. NW103 Sit Up
- 2. NWSW108 Tire Flip
- 3. NWSW109 Horizontal Ladder
- 4. NWSW110 Dual Bar
- 5. NWSW112 Step Blocks
- 6. NWSW114 Triple Pull Up with rings
- 7. NW503 Sign



Norwell Urban 1
(minimum 77m²)

- 1. NW103 Sit Up
- 2. NW105 Bar
- 3. NW107 Dual Pull Up
- 4. NW203 Stepper
- 5. NW401 Stretch
- 6. NW503 Sign

A fitness park without moving parts requires a minimum of maintenance.



Norwell Urban 2
(minimum 22m²)

- 1. NW104 Pull Up
- 2. NW301 Twister
- 3. NWC603 Combi-1
- 4. NW503 Sign

A fitness park without moving parts requires a minimum of maintenance.



Norwell Functional Training
(minimum 51,3m²)

- 1. NW201 Air Walker
- 2. NW202 Cross
- 3. NWC608 Functional Training Frame
- 4. NW503 Sign



Welcome to a world of outdoor fitness & play



All the fitness equipment is available in two materials.



Standard powder coated steel



Premium stainless steel

Danish design

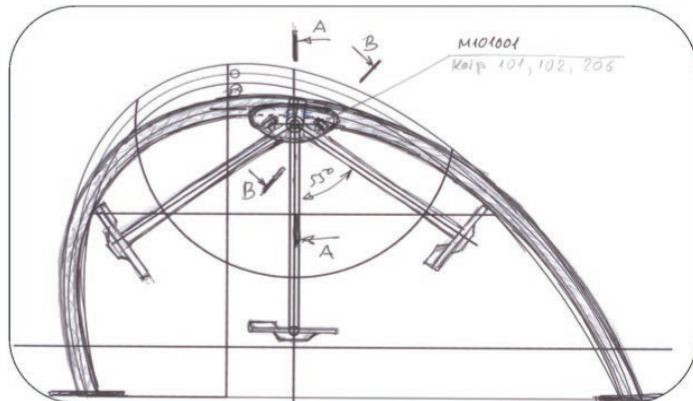

 **NORWELL**
OUTDOOR FITNESS & PLAY

www.norwelloutdoorfitness.com