





magourban

custom-made...

Magourban pone a tu disposición todo el conocimiento, experiencia e infraestructura industrial para fabricar cualquier elemento de mobiliario urbano o arquitectónico.

Magourban places all its knowledge, experience and infrastructures at your disposal for manufacturing any element for urban or architectural furniture.

Magourban posa a la teva disposició tot el coneixement, experiència i infraestructura industrial per fabricar qualsevol element de mobiliari urbà o arquitectònic.

Magourban met à votre disposition toute la connaissance, l'expérience et l'infrastructure industrielle pour fabriquer tout type d'élément de mobilier urbain ou architectural.

Paseo del Espigón Norte, Puerto de Gandía.





**“Manufacturing
your
designs”**





**“Adapting to
your needs”**



Petra Collection



bancos
bancs
benches
bancs



Abellir
53



Bali
53



Barrera
102



Drakkar
42



Dynamic
126



Flip-it
50



Gandhi
110



Bécquer
120



Beta
104



Blink
26



Bloop
86



Gaviotas
64



Geométrico
43



Grap
56



Gregal
53



Borneo
53



Bus
130



Coma
35



Confeti
36



Guipúzcoa
114



Hache
66



K-3
113



Luce
34



Crusöe
62



Cuc
44



Dish
51



Dove
106



Manyanet
58



MDT
116



Mesull
55



Modulblock
119

bancos
bancs
benches
bancs



Nú
112



Olive
70



Ona
68



Sentarse con los árboles
122



Sit-up
60



Sol
118



Targa
74



Origami
48



Pausa
71



Pilosilla
46



Ponte
124



Tetris
76



Tippy
82



Tube
92



Ubloc
47



Poupées russes
72



Practic
91



Public
28



Recte
90



Unió
108



Unit
52



Urgell
54



Vinyes
94



Ripple
38



Sassi
80



Sedàs
54



Segrià
54



Waves
96



Zen
98

jardineras
jardineres
planters
jardinières



Cantorodado
136



Ese
150



Espace
152

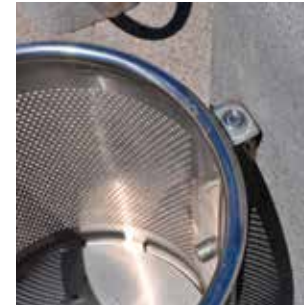

recogida residuos
recollida residus
waste collection
collecte de déchets
154



límites
límits
bollards
limites
166



pícnic
pícnic
picnic
pique-nique
176



Fuat
138



Granpot
140



Hex
139



Malva
142



Tanit
134



Uve
146



Zaphir
151



33 - 34
147



pavimentos
paviments
pavements
revêtements
186



miscelánea
miscelània
miscellaneous
divers
210



accesorios
accessoris
accessories
accessoires
216



69
148



78
149



143
149



344N - 349N
148



bancos
bancs
benches
bancs



Blink

by Ton Riera

Asientos que dotan de ligereza y amplitud a los espacios urbanos. Un mobiliario que respira y brilla con luz propia.

Seats that give urban spaces a light, spacious feel. Furniture that breathes and shines with a light of its own.

Seients dissenyats per donar lleugeresa i amplitud als espais urbans. Un mobiliari que respira i brilla amb llum pròpia.

Des sièges qui apportent légèreté et amplitude aux espaces urbains. Mobilier qui respire et brille par lui-même.

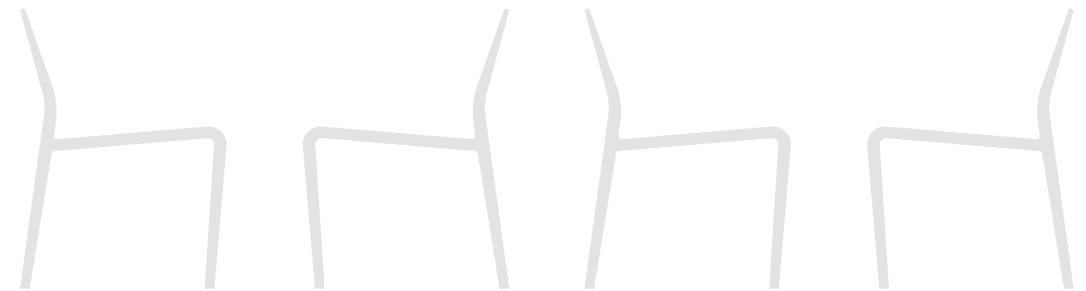

Blink B

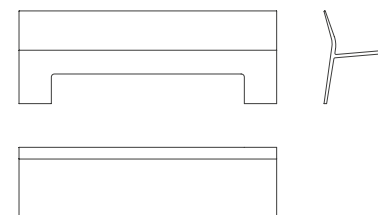

200 cm

Blink C

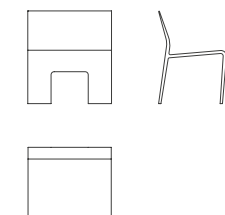



Public by losdíez
inclusive design, design for all...

Dos conceptos en un mismo diseño.

Extender y deslizar son los dos conceptos que se han fusionado a la hora de diseñar Public, un banco de hormigón UHPC formado por dos patas o brazos centrales de los cuales se sostienen dos asientos laterales y uno central, facilitando así el uso de este último en el momento crítico de tomar asiento o levantarse, sobre todo a los sectores sensibles de la población como son los ancianos, discapacitados, embarazadas o personas con sobrepeso.

Al mismo tiempo, el hecho que los asientos laterales no estén limitados por su parte exterior permite aumentar su ancho proporcionando una mayor amplitud respecto a la plaza localizada entre apoyabrazos.

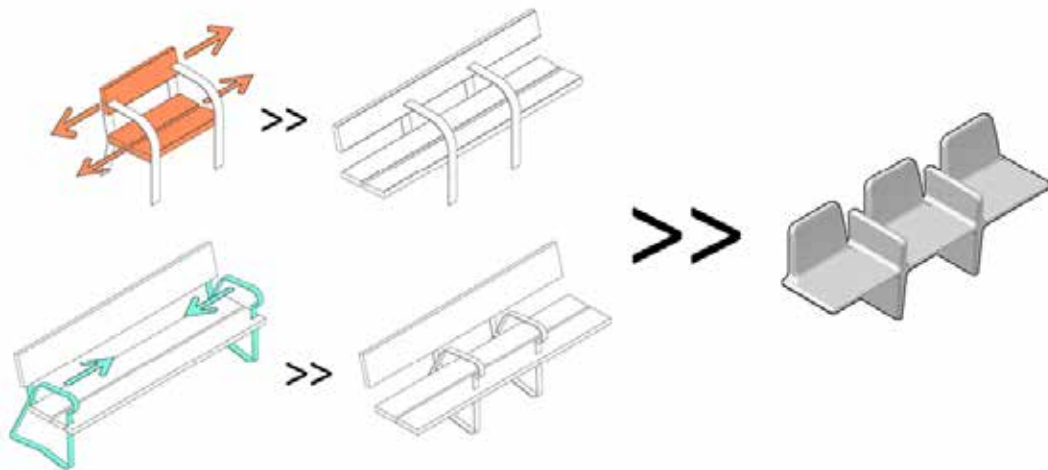

Two concepts in one design.

Extending and sliding are the two concepts that have merged at the time of designing Public, a UHPC concrete bench formed by two legs or central arms from which two lateral seats and one central seat are supported, thus facilitating its use by the latter at the critical moment of taking a seat or getting up, above all to the sensible sectors of the population such as the elderly, the disabled, pregnant women or overweight people.

At the same time, the fact that the side seats are not limited on the outside makes it possible to enlarge their width by providing a greater width with the seating position located between the armrests.



Public _ losdéz

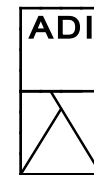

ADI - FAD
2016



Premio
Diseño para todas las
personas / Fundación ONCE



Public



Public 3P

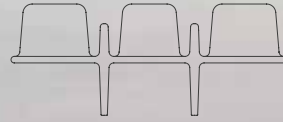

210 cm

Pensar en el mobiliario urbano es pensar en la gente.

Cuando se construye o reforma cualquier calle, plaza, parque, etc, los ciudadanos se adaptan a lo impuesto por los profesionales del diseño y las instituciones que lo llevan a cabo. Previamente dichos "interventores" de los proyectos nos hemos preocupado e interesado por las necesidades y hábitos de las personas en relación al uso del espacio público ya que es en este lugar donde se establecen las relaciones con el mundo exterior, fuera del trabajo y del hogar.

Ofreciendo una amplia gama de posibilidades en cuanto a la orientación y las relaciones proxémicas, Public se ha convertido en el claro ejemplo que refleja el diseño inclusivo, para todos.



To think about urban furniture is to think about people.

When building or renovating any street, square, park, etc., citizens adapt to what is imposed by design professionals and the institutions that carry it out. However, we have been concerned and interested in the needs and habits of people in relation to the use of public space, since it is in this place where relations are established with the outside world, outside of work and home.

Offering a wide range of possibilities in terms of orientation and proxemic relationships, Public has become the clear example that reflects inclusive design, for all.

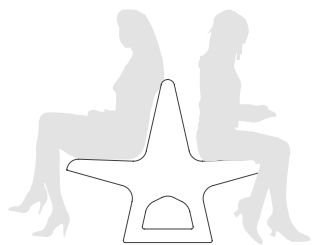

Luce

by Jesús Alfaro, Ana Hurtado



Estrellas modulares que forman un banco a dos caras y que se adaptan con facilidad a diferentes entornos.

Estels modulars que formen un banc a dues cares que s'adapta amb facilitat a diferents entorns.

Modular stars that form a two-sided bench, easily adaptable to different environments.

Étoiles modulaires formant un banc double face qui s'adapte facilement à différents environnements.

Luce



Luce R

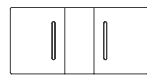

Luce 19

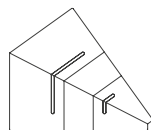

Luce 27

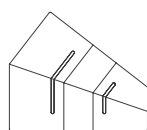

Un asiento que incita a realizar una pausa en el camino.

Un seient que convida a fer una pausa en el camí.

A seat that invites you to stop and take a break along the way.

Un siège qui invite à faire une pause sur le chemin.

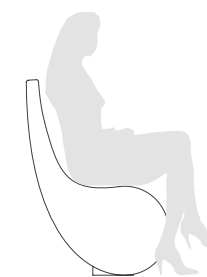

Coma

by Joan Cinca

Confeti

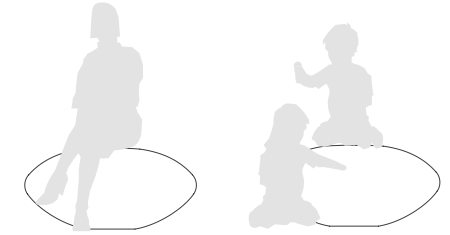

Salpica de diversión cualquier espacio, haz de tu ciudad una fiesta.

Esquitxa de diversió qualsevol espai, fes de la teva ciutat una festa.

Splashes of fun anywhere; turn your city into a party.

Du divertissement parsemé dans tout type d'espace pour que votre ville soit en fête.





Ripple

by In-Tenta design + Daniela Seminara

large-format bench inspired by desert...

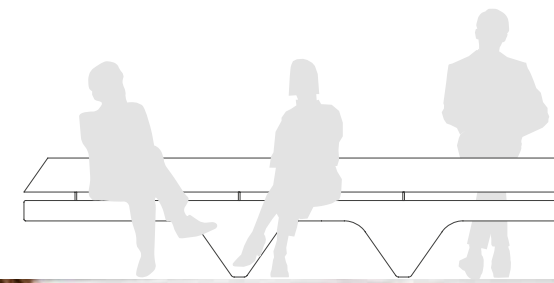
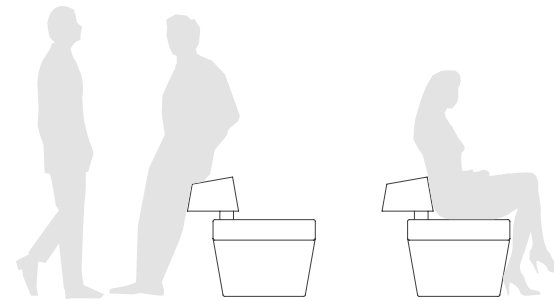

Banco de gran formato inspirado en los 'Ripples', pequeñas dunas formadas por granos de fina arena transportados por el viento del desierto.

Banc de gran format inspirat en els 'Ripples', petites dunes formades per grans de fina sorra transportats pel vent del desert.

Large-format bench inspired by 'Ripples', small dunes formed by grains of fine sand transported by the desert wind.

Banc de grande taille inspiré par les « Ripples », de petites dunes constituées de fins grains de sable transportés par le vent du désert.

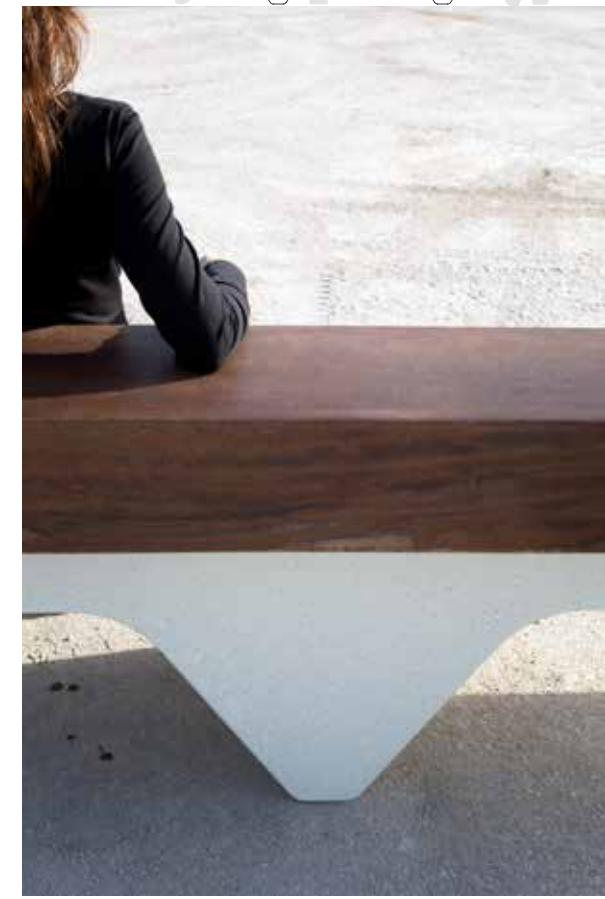

Ripple BR 240 | Ripple BR 350

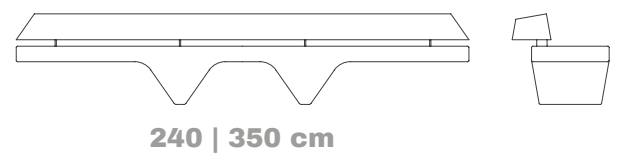

Ripple B 240 | Ripple B 350

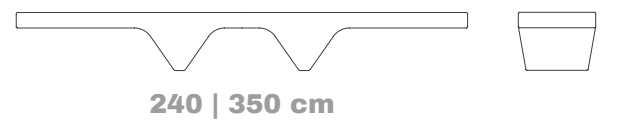

La unión idílica entre el hormigón y la madera.

La unió idíl·lica entre el formigó i la fusta.

The idyllic combination of concrete and wood.

La combinaison idyllique entre le béton et le bois.

Drakkar

by Den Studio

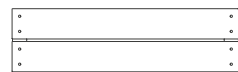

180 cm



Ensalzando espacios para vivir, preciso y simétrico.

Enaltint espais per viure, precís i simètric.

Exalting spaces to live, with its precision and symmetry.

Exaltation des espaces à vivre, grâce a sa forme précise et symétrique.

Geométrico B

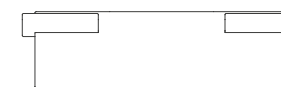
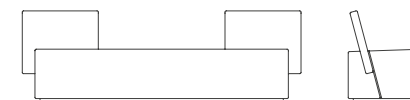

220 cm

Geométrico C

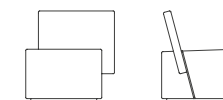

Geométrico

by Cristina Noguera, Joaquim Roqué, Josep Motas

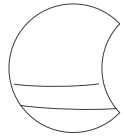

Cuc

by Foreign Office Architects
Farshid Moussavi, Alejandro Zaera Polo
special thanks to Kenichi Matsuzawa

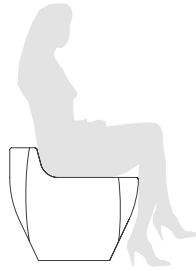

Articula el espacio para compartirlo individualmente.

Articula l'espai per compartir-lo individualment.

Articulate the space to share it individually.

Articule l'espace pour le partager individuellement.

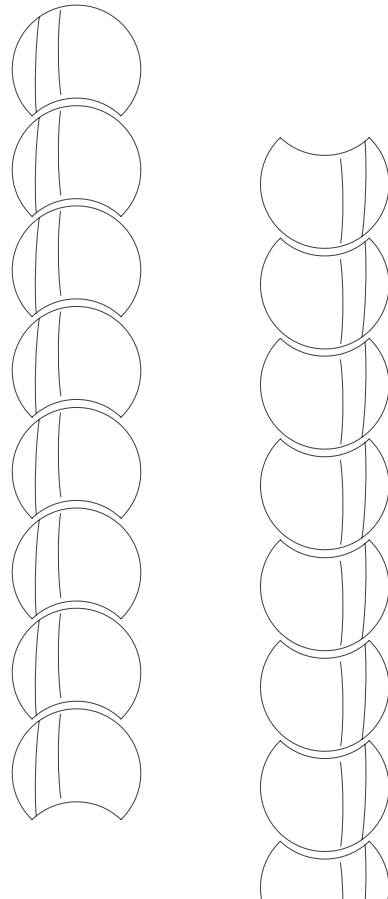

ADI - FAD
2005

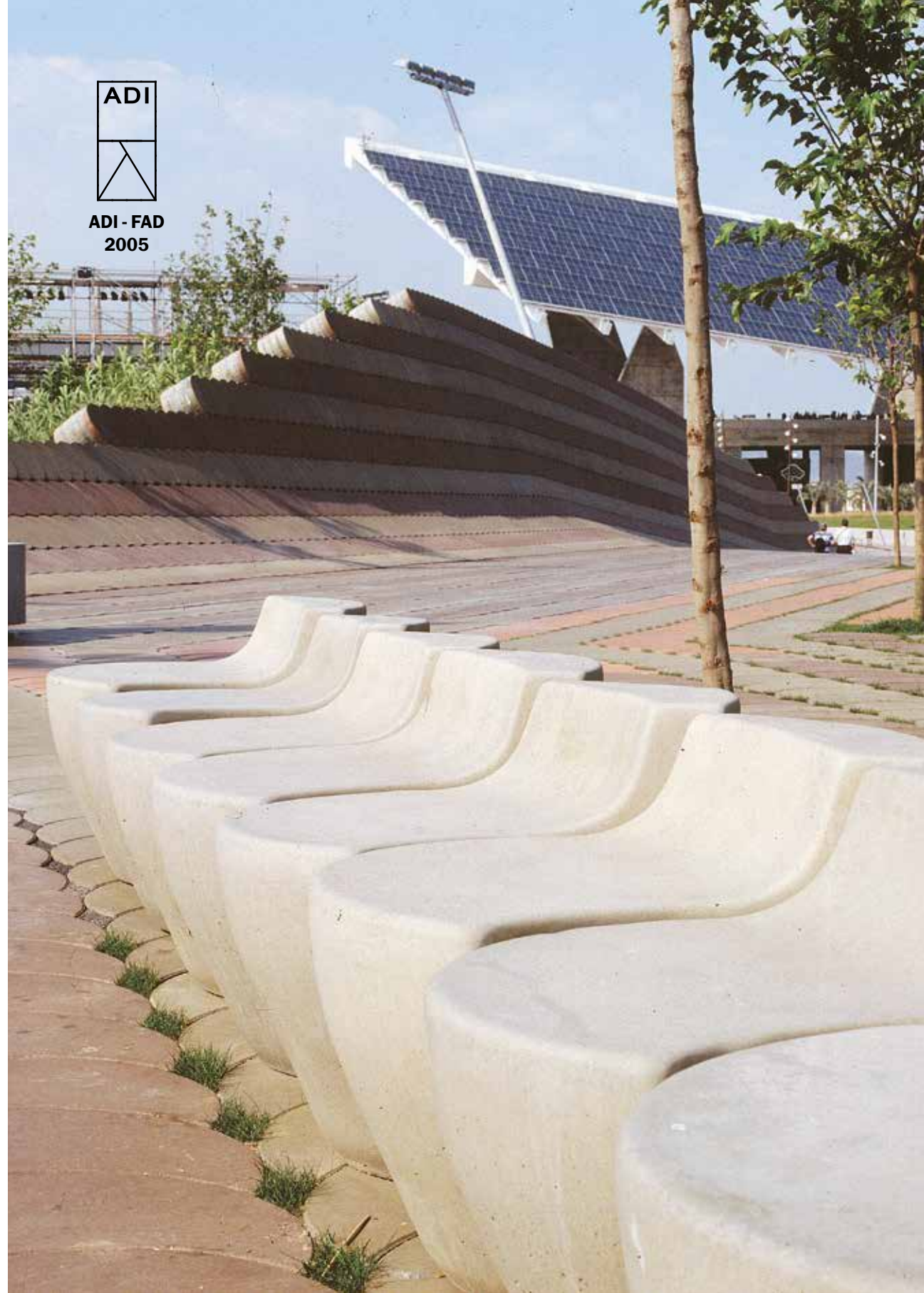

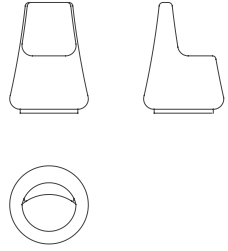

Pilosilla

by SUMA Arquitectes

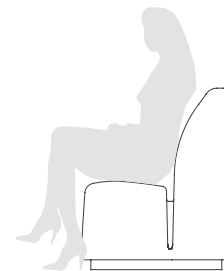
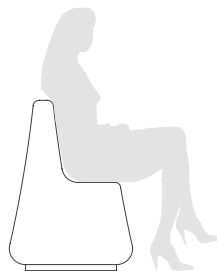

Mobiliario sólido y contundente que elimina cualquier indecisión.

Mobiliari sòlid i contundent que no deixa espai a la indecisió.

Solid and blunt urban furniture that rules out all indecision.

Mobilier solide et percutant qui ne laisse pas le moindre doute.

Ubloc

by Xavi Ferrús

Origami

by Ernest Perera



Origami es el arte nipón de doblar papel y ahora es también la técnica de doblar el hormigón.

Origami is the Japanese art of folding paper, and now it's also the technique of folding concrete.

Origami és l'art japonès de doblegar paper i ara és també la tècnica de doblegar el formigó.

L'origami est l'art japonais du pliage du papier, une technique désormais applicable au béton.



Origami BR

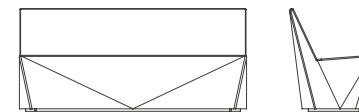

180 cm

Origami J | 250 L

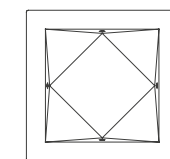
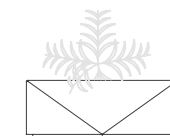

120

120 cm



Jardinera de gran formato para crear volúmenes verdes.

Jardinera de gran format per crear volums verds.

Large-format planter to create green volumes.

Jardinière de grande taille pour créer des volumes verts.

Dish

by Guido Marsille

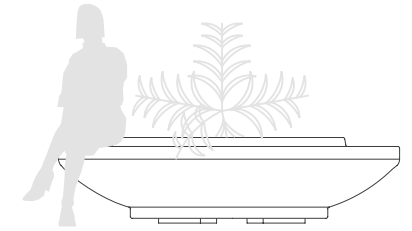

Ø 190 cm
335 L



Flip-it

by La Noche de la Iguana
Kiko Solsona

Banco y jardinera, combínalos.

Banc i jardinera, combína'ls.

Bench and planter, combine them.

Banc et jardinière, combinez-les.

Flip-it B

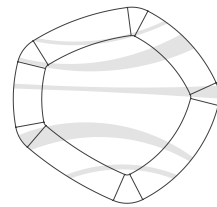

Flip-it J | 350 L

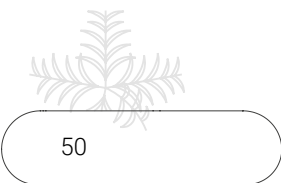
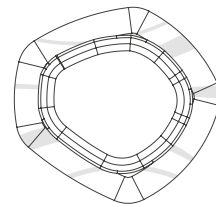

50

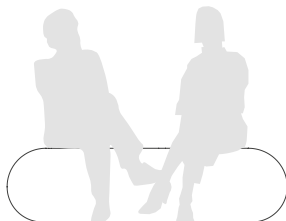

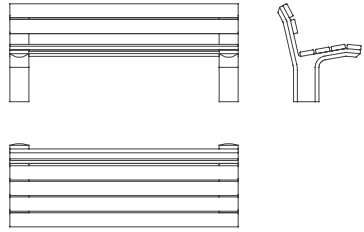

180 cm

Unit

by Ernest Perera



Abellir

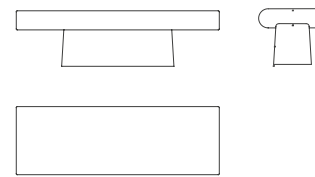

170 cm

Gregal

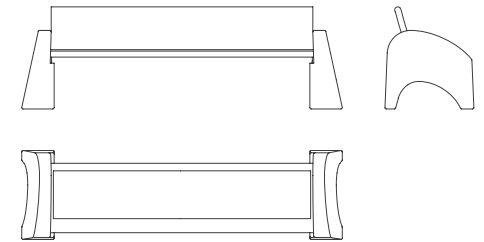

250 cm



Bali

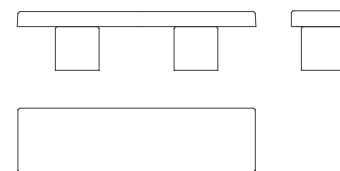

190 cm

Borneo

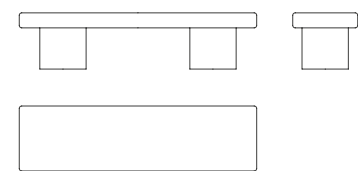

190 cm



Segrià

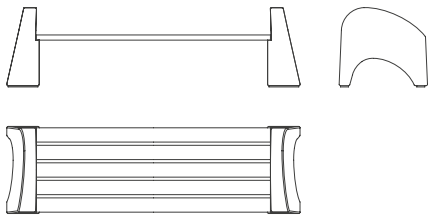

226 cm



Urgell

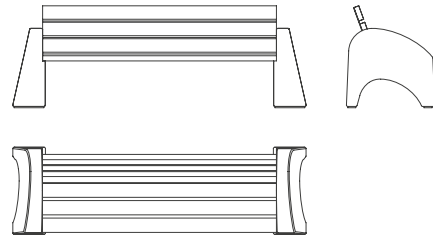

226 cm



Mesull

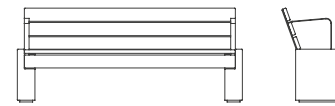

Mesull SR



177 cm

Mesull



Sedàs

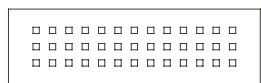

200 cm



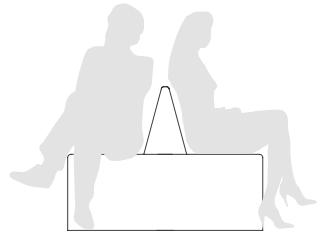

Grap

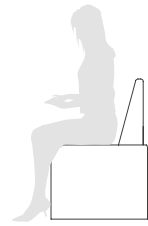

Formas orgánicas de la naturaleza que colonizan la ciudad y rompen con la rigidez de la trama urbana.

Organic shapes inspired by nature that colonise the city and break with the rigidity of the urban pattern.

Formes orgàniques de la natura que colonitzen la ciutat i trenquen amb la rigidesa de la trama urbana.

Formes organiques de la nature qui colonisent la ville et rompent avec la rigidité du tissu urbain.

Grap G

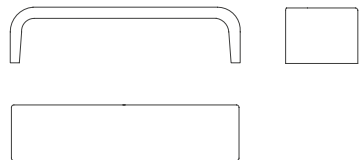

184 cm

Grap P

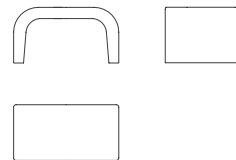

85 cm

Grap C

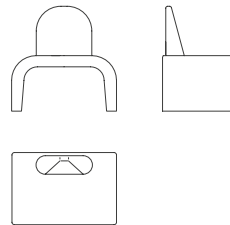

85 cm

Grap R

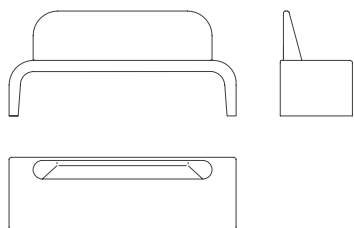

184 cm

Grap duo

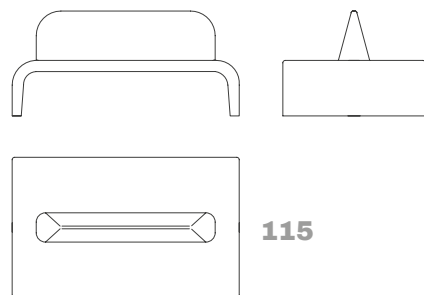

115

184 cm

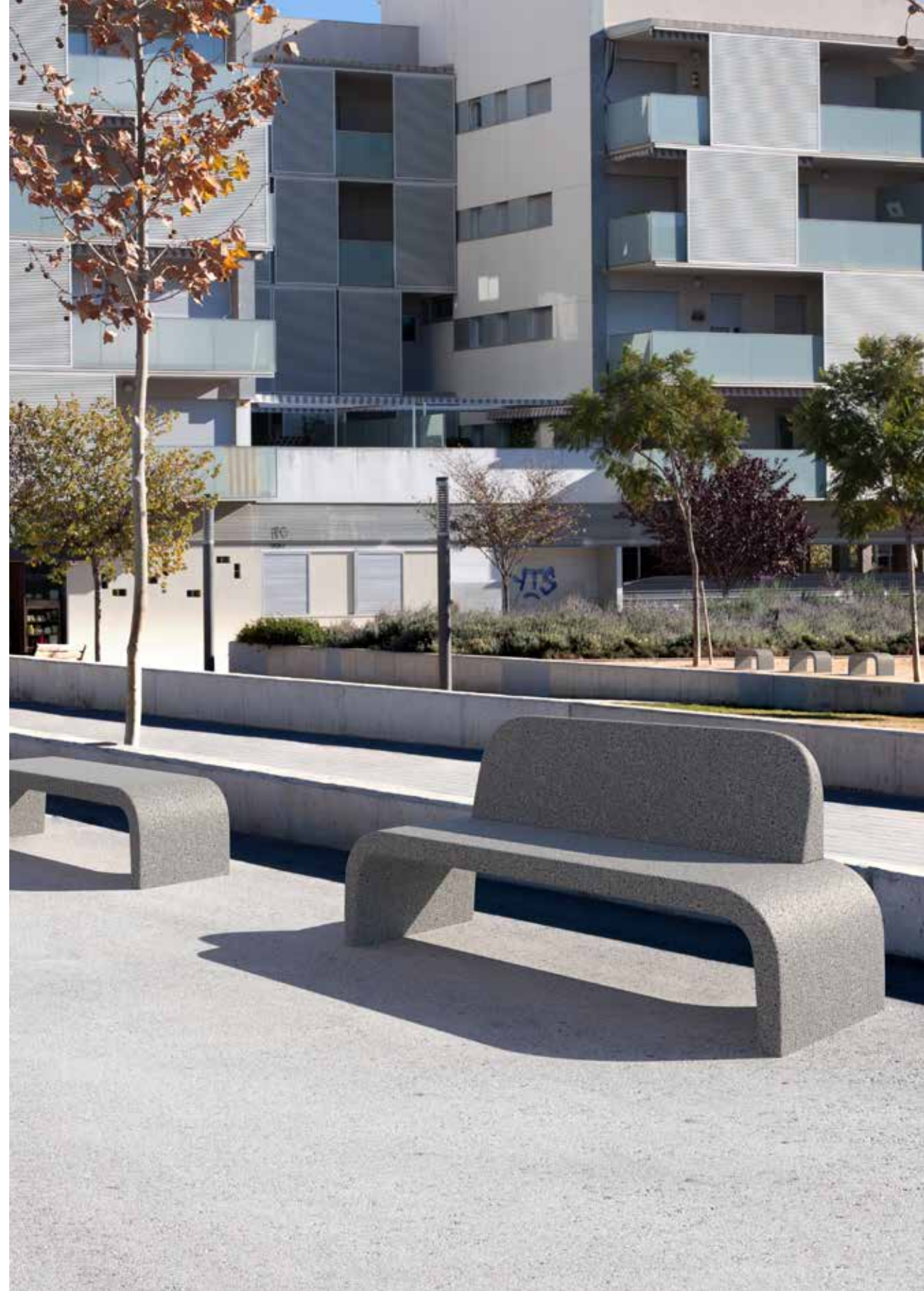



Manyanet



Manyanet aire



Manyanet aire

Manyanet

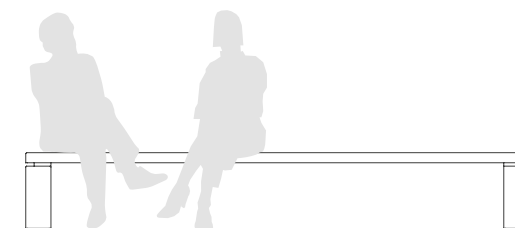

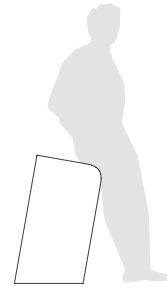

Sit-up

by Alòs Idees

A menudo la sencillez y la multifuncionalidad pueden ir de la mano. Elemento con el que podemos decorar, limitar, iluminar y hacer una pausa.

Simplicity and multifunctionality can often go hand in hand. This element can be used to decorate, illuminate and for a short break.

Sovint la senzillesa i la multifuncionalitat poden anar juntes. Element amb el qual podem decorar, limitar, il·luminar i fer una pausa.

La simplicité et la polyvalence peuvent souvent aller de pair. Avec cet élément, il est possible de décorer, de délimiter, d'éclairer et de faire une pause.



Sit-up stool

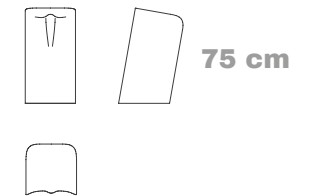

Sit-up light

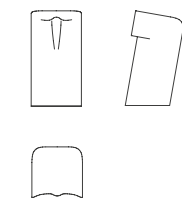

DELTA AWARDS '14

Selected



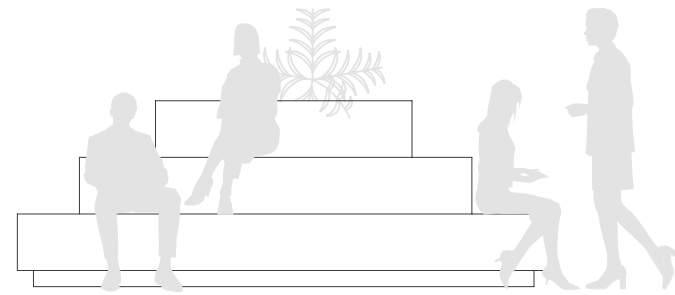

Crusöe

by Roger Albero

Una isla en medio de la urbe.
Ocupa espacios en diferentes alturas.

Una illa enmig de la urbs. Ocupa espais en diferents alçades.

*An island in the middle of the city.
Filling spaces at different levels.*

*Une île en plein cœur de la ville.
Occupe les espaces à différentes hauteurs.*

Crusöe C | 248 L



Crusöe B | 338 L

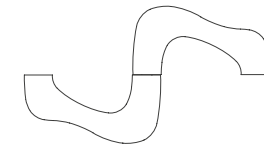
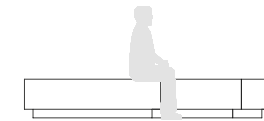
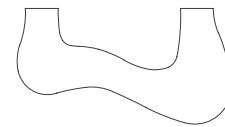

Crusöe A | 709 L

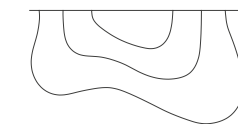
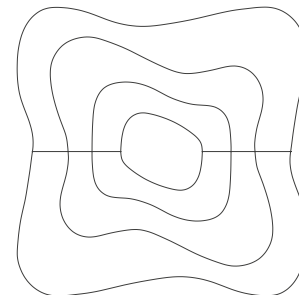
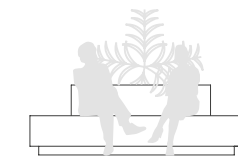
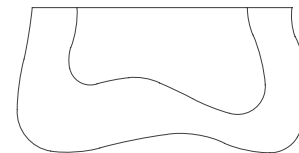

330 cm



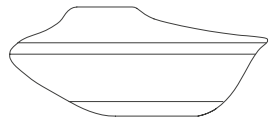
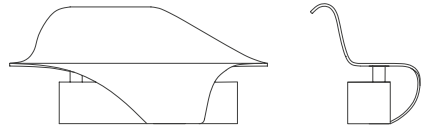

200 cm

Gaviotas

by Ewald Winkelbauer

Nuestro banco más onírico, de naturaleza tranquila y silenciosa que sugiere a una gaviota batiendo sus alas hacia la libertad.

Our dreamiest bench, peaceful and silent, looking like a seagull flapping its wings towards freedom.

El nostre banc més oníric, de naturalesa tranquil·la i silenciosa que suggereix a una gavina batent les seves ales cap a la llibertat.

Notre banc le plus onirique, qui rappelle une mouette battant des ailes vers la liberté.

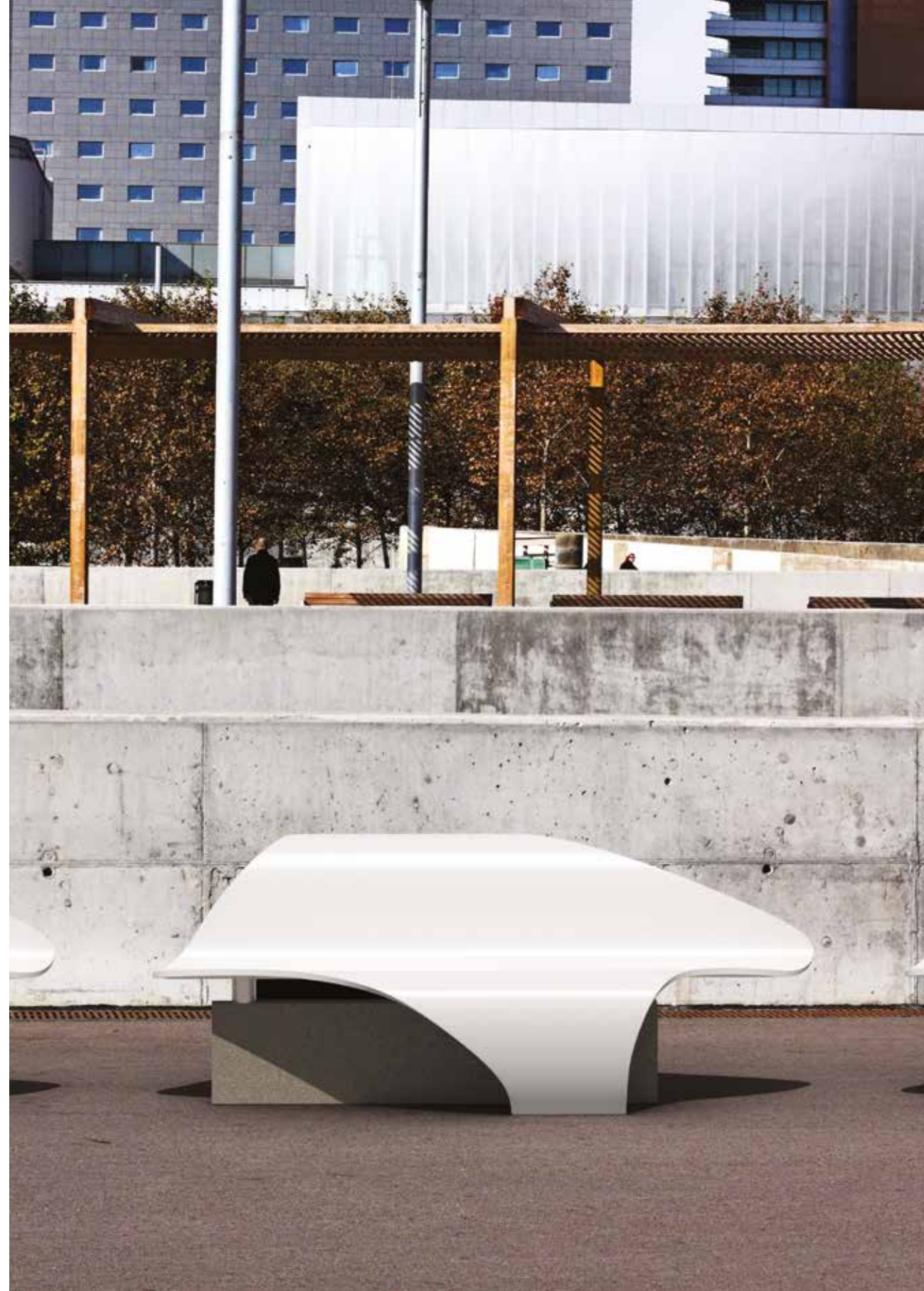

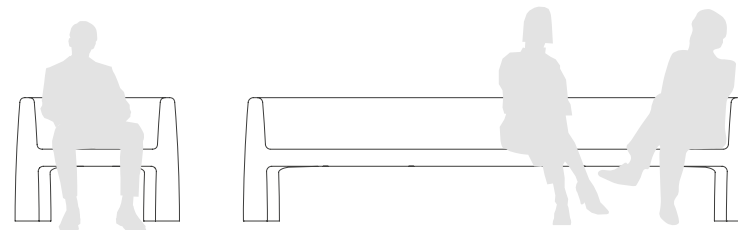

Hache

by Ernest Perera

Asientos que insinúan los antiguos 'tú y yo', ideales para crear espacios acogedores.

Seats with a nod to the old-fashioned loveseat - perfect for creating welcoming spaces.

Seients que insinuen els antics 'tu i jo', ideals per crear espais acollidors.

Sièges qui évoquent les « vis-à-vis » d'antan, idéals pour créer des espaces accueillants.

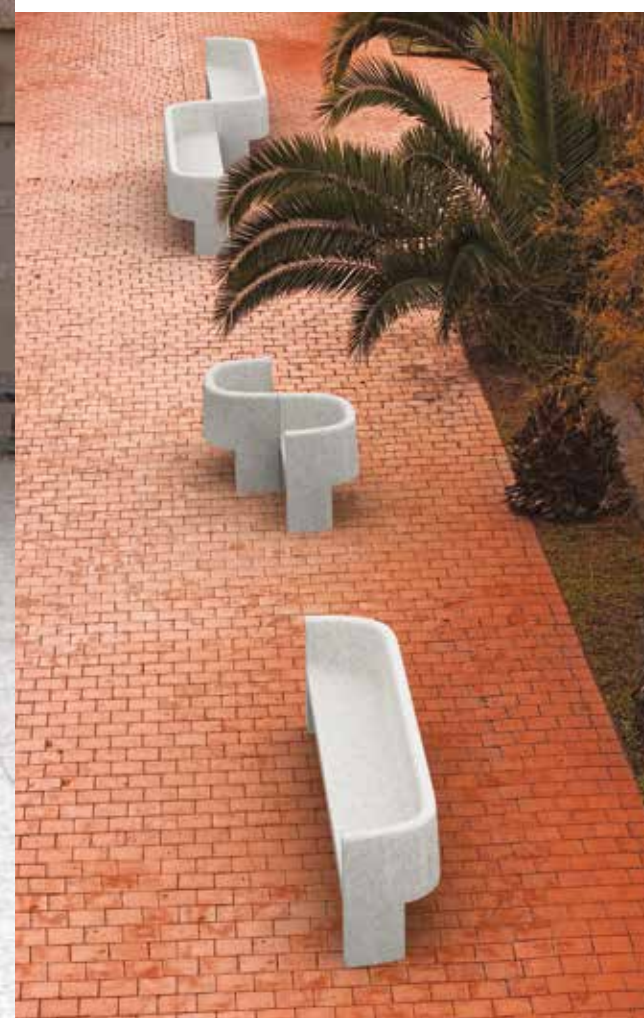

Hache CN

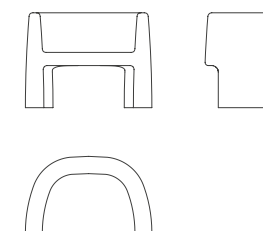

Hache BN

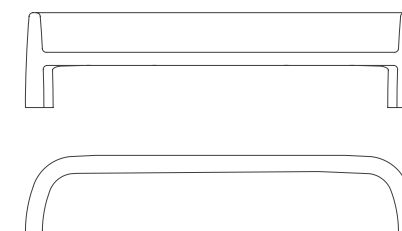

300 cm

Ona

by Oriol Pardo

Elementos curvilíneos y sugerentes que suavizan los espacios.

Curvilinear and suggestive elements that soften spaces.

Elements curvilinis i suggerents que suavitzen els espais.

Éléments curvilignes et suggestifs qui adoucissent les espaces.

Ona cóncavo

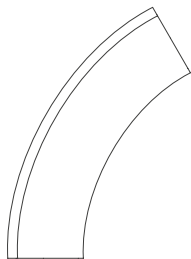
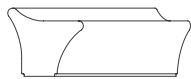

Ona convexo

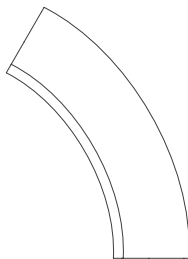
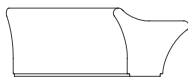

Ona recto



200 cm

Ona C 90

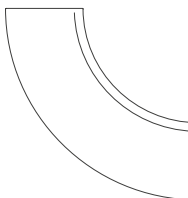

Ona C 90

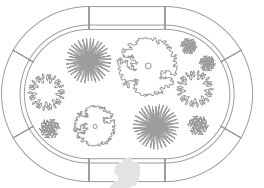

**Ona convexo
Ona recto**

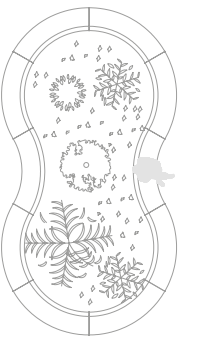

**Ona cóncavo
Ona convexo**

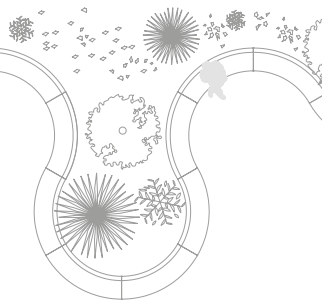

Olive

by Bow Design

Olive OL

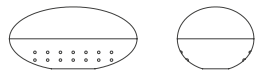

light

Olive OB

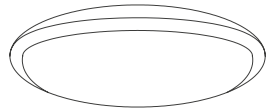
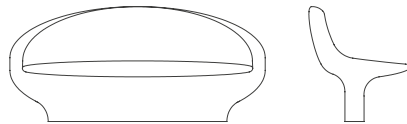

200 cm

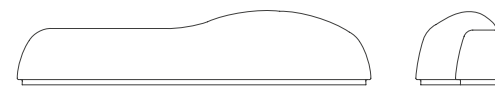

270 cm



Pausa

by Oriol Guimerà

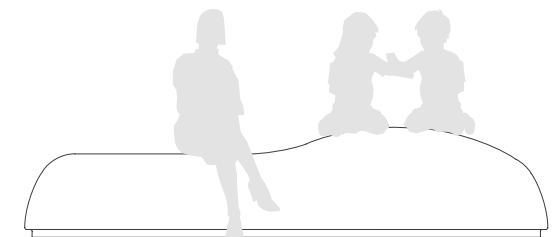



Poupées russes

by Kutarq studio + YHY design

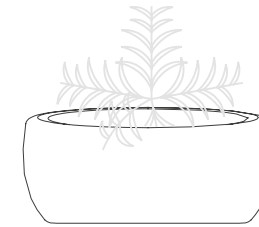
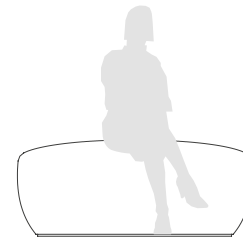

Juega con volúmenes y deja volar tu creatividad.

Juga amb volums i deixa volar la teva creativitat.

Play with volumes and let loose your creativity!

Jouez avec les volumes et laissez parler votre créativité.



Russes J 71 | 88 L

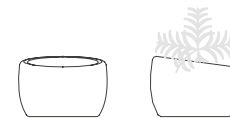

Ø 71 cm

Russes J 130 | 210 L

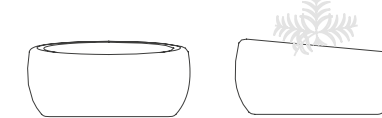

Ø 130 cm

Russes pouf



Ø 120 cm



Targa

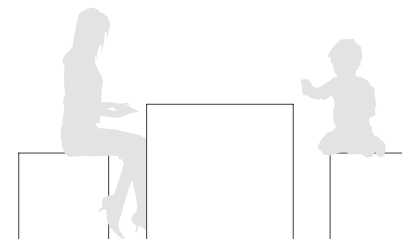

Una declaración clásica con una geometría simple y pura.

A classic statement with simple, pure geometry.

Una declaració clàssica amb una geometria simple i pura.

Une déclaration classique avec une géométrie pure et simple.

Targa T 77
Targa T 110



200 cm

Targa B
Targa B 50

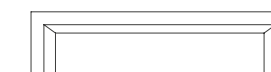

200 cm

Targa C

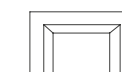

80 cm





Tetris

by Roger Albero

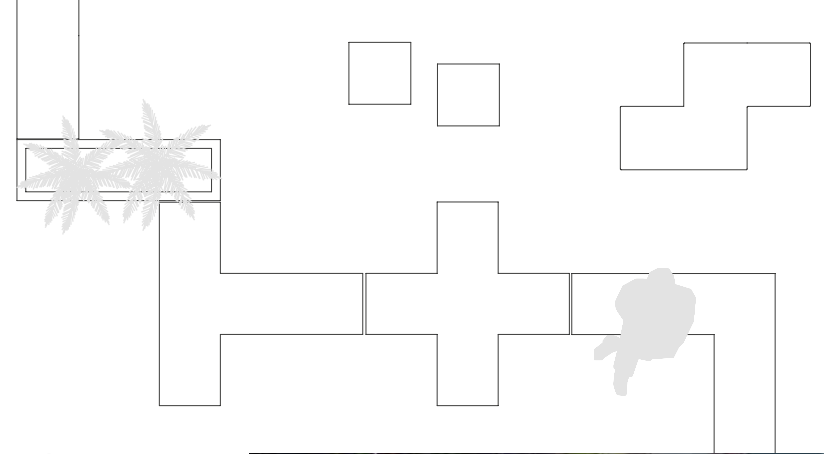

Para jugar, encajar y combinar en libertad.

Per jugar, encaixar i combinar en llibertat.

To play, to fit together and to combine as you wish.

Pour jouer, assembler et combiner en toute liberté.

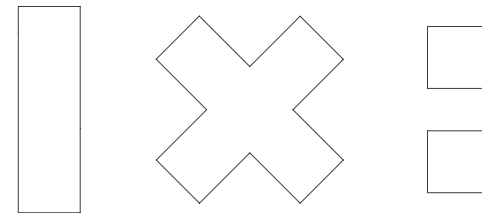

Tetris I 90 | Tetris I 150 | Tetris I 220



90 | 150 | 220 cm

Tetris Q | Tetris Q 90



45 | 90 cm

Tetris C

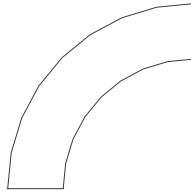

150 cm

Tetris T

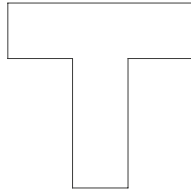
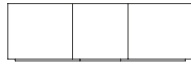

150 cm

Tetris X

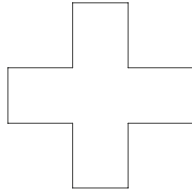

150 cm

Tetris O



150 cm

Tetris L

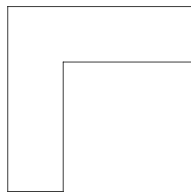

150 cm

Tetris Z1

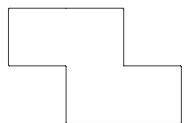

135 cm

Tetris Z2

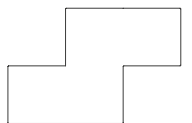

143 cm

Tetris O plus

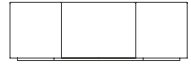

Tetris C30



215 cm

**Tetris J 120 | 110 L
Tetris J | 147 L**



120 | 150 cm

Tetris L vertical | 150 L

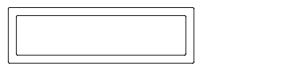

150 cm

90



Tetris _ Roger Albero

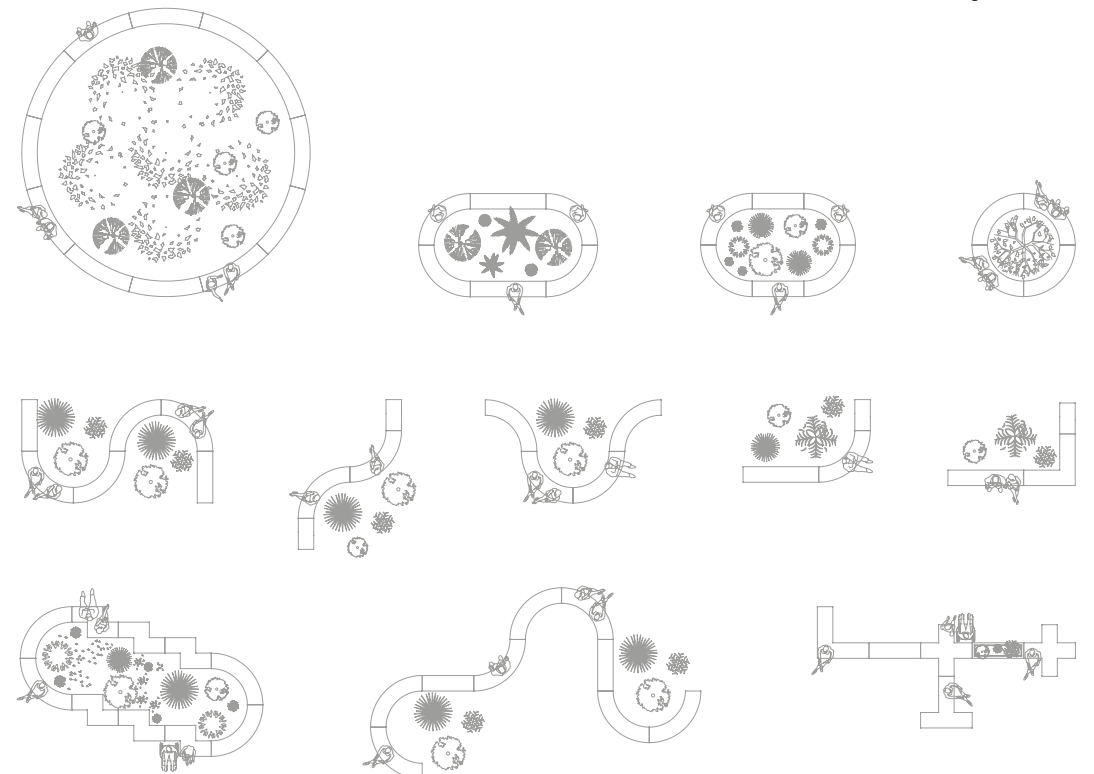

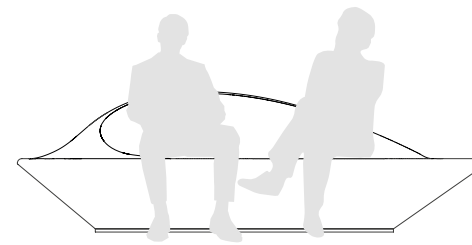

Sassi

by Ton Riera

Sassi J

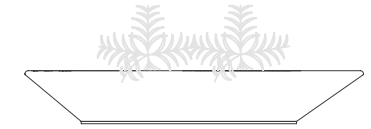

Barcas de hormigón ancladas en tierra firme.

Barques de formigó ancorades en terra ferma.

Concrete boats anchored on land.

Bateaux en béton ancrés à terre.

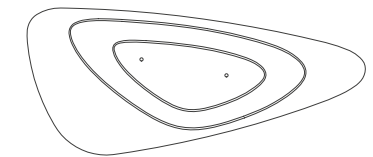

260 cm

Sassi

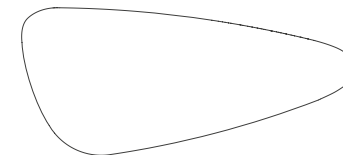

Sassi R

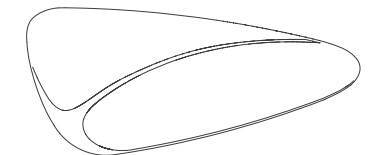
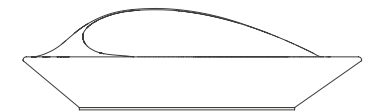

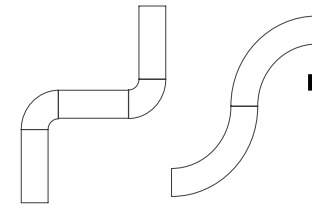
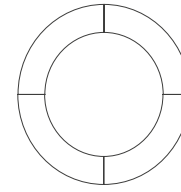
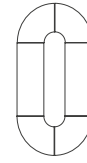
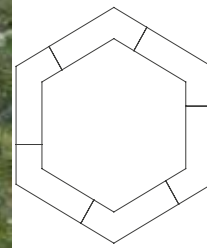

Tippy

by Ton Riera

Serie de elementos combinables para trazar límites y bancos de formas redondeadas y sensuales.

A serie of elements that can be combined to draw boundaries and benches with round and sensual shapes.

Sèrie d'elements combinables per traçar límits i bancs de formes arrodonides i sensuales.

Série d'éléments modulaires pour délimiter et former des bancs aux formes arrondies et sensuelles.

Tippy V

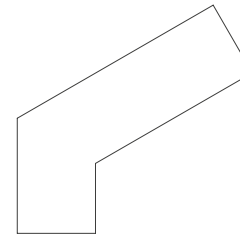

Tippy B



110 | 160 | 220 cm

Tippy R 23

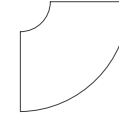

Tippy R 136

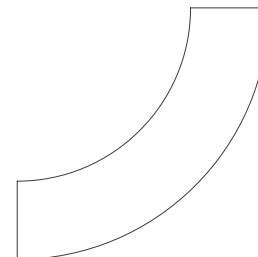

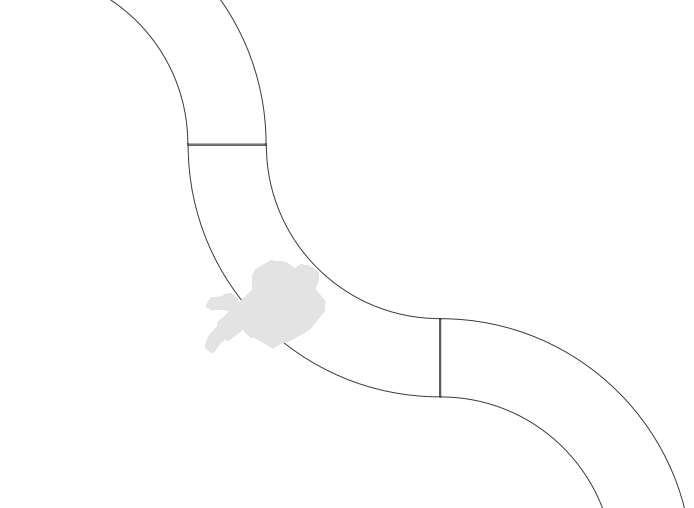

Tippy gap B 220



220 cm

Tippy gap R 136

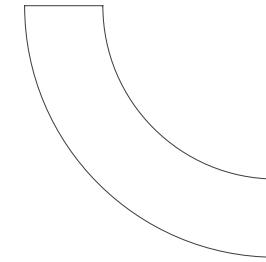

Bloop

by Ton Riera

Elegancia y robustez en un mismo elemento.

Elegance and strength in the same piece.

Bloop 2m

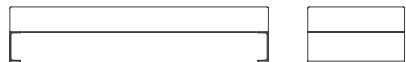

200 cm

Bloop 3m

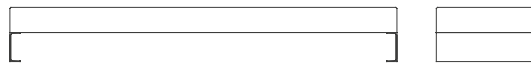

300 cm

Bloop 4m

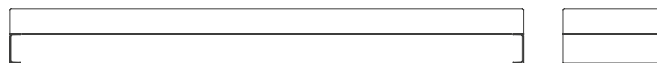

400 cm

Elegància i robustesa en un mateix element.

Élégance et robustesse en un seul élément.

Bloop R

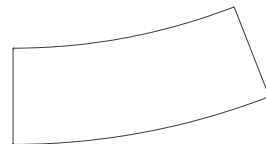
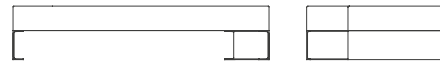

Bloop 3m + Plus 2







Practic

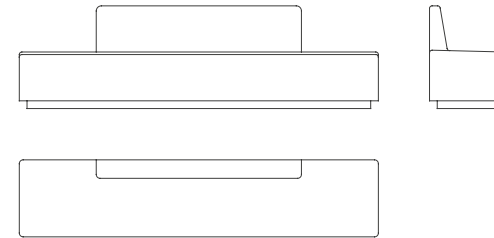

280 cm

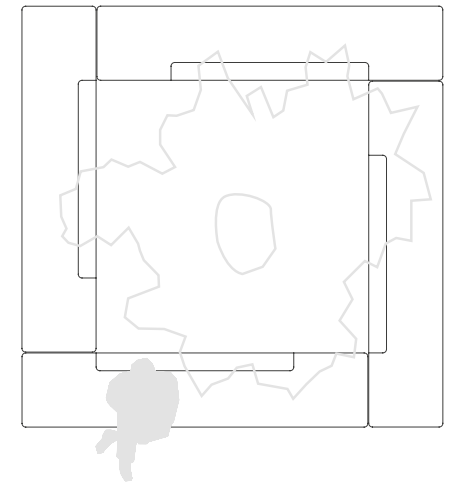

Recte

by Ton Riera

Recte es un sofá que proporciona confort en medio de la ciudad. Siéntate como en casa.

Recte és un sofà que proporciona confort enmig de la ciutat. Seu com a casa.

Recte is a sofa that provides comfort in the middle of the city. Sit down, just like at home.

Recte c'est a sofà qui donne du confort au milieu de la ville. Asseyez-vous et faites comme chez vous.

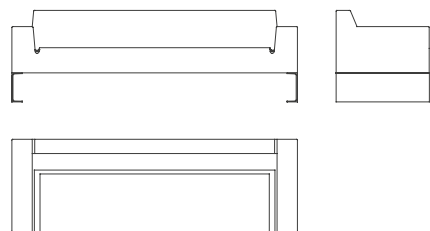

236 cm

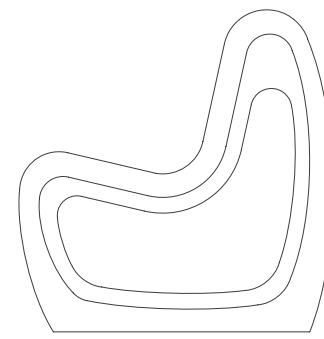

Tube

by Roger Albero

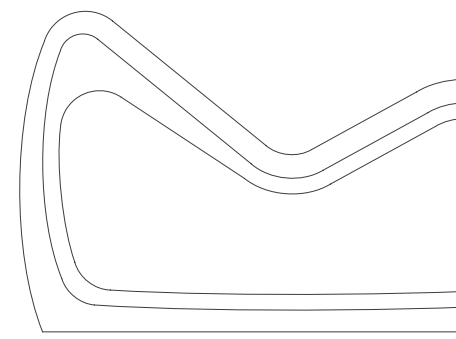

Esencial, mínimo, sólo una línea de hormigón y el espacio vacío.

Essential, minimalist: just a line of concrete and an empty space.

Essencial, mínim, només una línia de formigó i l'espai buit.

Essentiel, minimaliste, juste une ligne de béton et de l'espace vide.

Tube tumbona

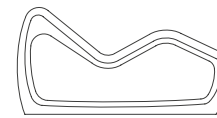

161 cm

Tube silla

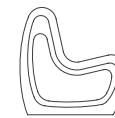

80 cm

Tube banca

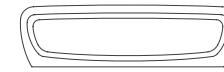

164 cm

Tube cubo



60 cm



Vinyes

by EMBT / Benedetta Tagliabue

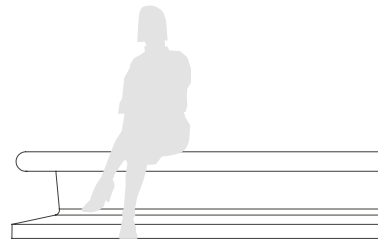
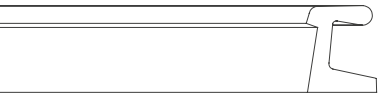

Banco, límite, barrera, muro de jardín... ordena el espacio.

Bench, boundary, barrier, garden wall... to organise the space.

Banc, límit, barrera, muret de jardí... ordena l'espai.

Banc, limite, barrière, mur de jardin... pour ordonner l'espace.



Vinyes I 160



160 cm



Vinyes R 726



Vinyes R 250

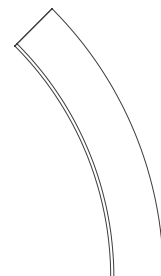
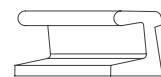

Vinyes R 333

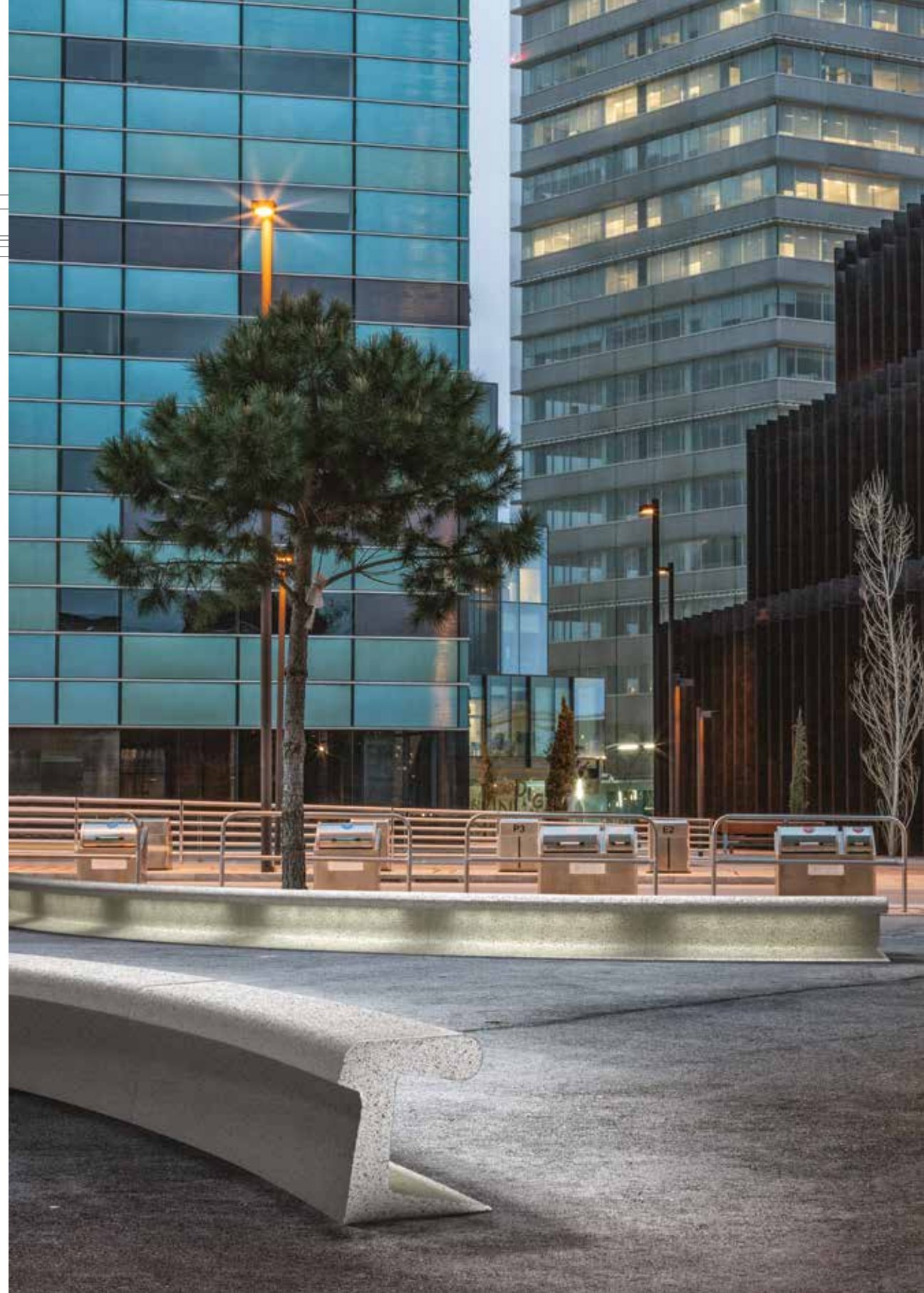
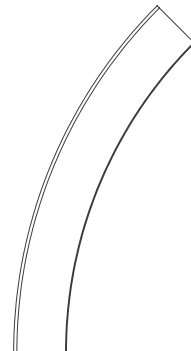
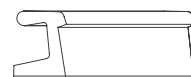

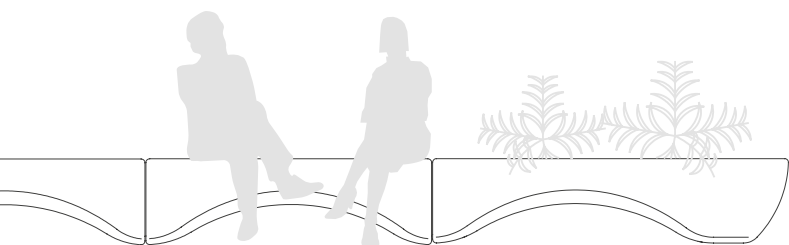

Waves

by Roger Albero

Waves B

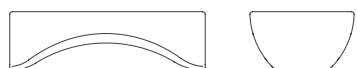

150 cm

Waves J | 295 L

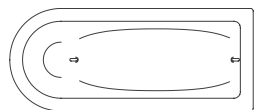

190 cm

Es un banco, es una jardinera, es un banco-jardinera. Para sentarse junto a la naturaleza.

És un banc, és una jardinera, és un banc-jardinera. Per seure vora la natura.

It's a bench. It's a planter. It's a bench-planter. To sit down next to nature.

C'est un banc, c'est une jardinière, c'est un banc-jardinière. Pour s'asseoir près de la nature.



Zen

by losdíz

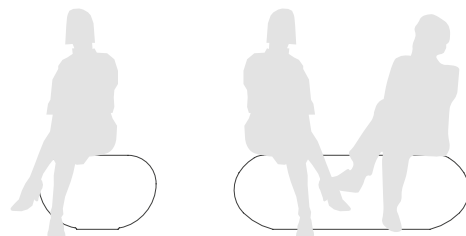

Elementos inspirados en los jardines zen, simplicidad elegante que invita a la calma.

Elements inspirats en els jardins zen, simplicitat elegant que convida a la calma.

Elements inspired by Zen gardens; elegant simplicity that invites tranquility.

Des éléments inspirés par les jardins Zen, une simplicité élégante qui invite à la sérénité.





Zen



Ø 65 cm

Zen duo



130 cm

Zen trio

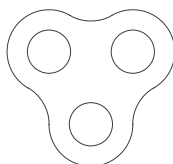

130 cm



Zen _ losdfez

Zen V



Zen V light



178 cm

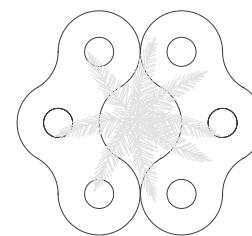
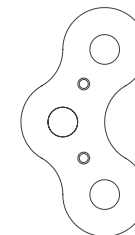

Zen V light _ losdfez

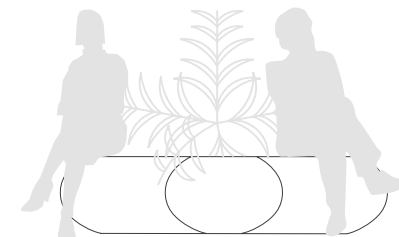



Barrera

by GCA Arquitectes Associats

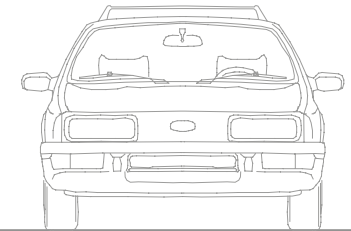
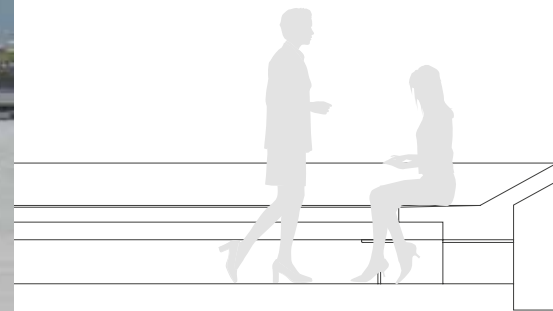

Líneas continuas, ligeras y de fuerte impacto sensorial.

Línies contínues, lleugeres i de fort impacte sensorial.

Thin, continuous lines and a strong sensory impact.

Dont les lignes continues et légères génèrent un fort impacte sensoriel.



Beta

by Miba architects + SiO2

Beta 144



144 cm

Beta 235



235 cm

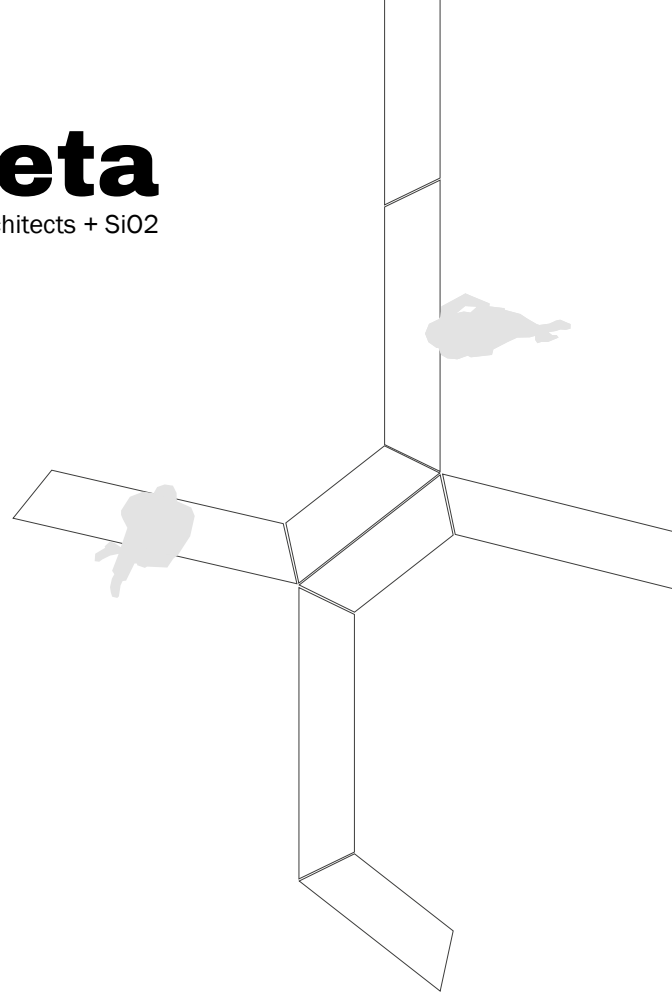

Dove pouf

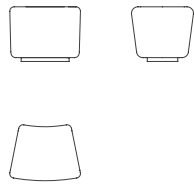

Dove cóncavo

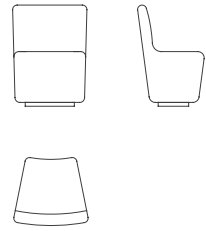

Dove convexo

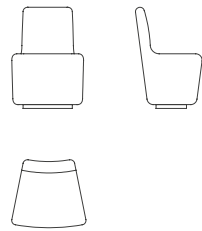

Dove J | 65 L

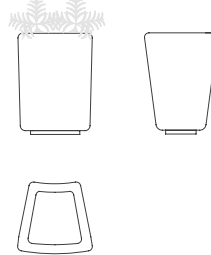

Dove

by losdíz

XIII
PREMIOS
AEPD

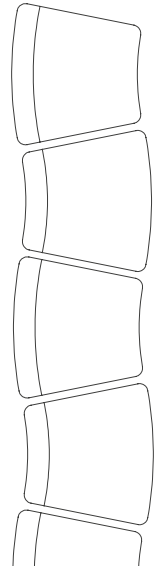
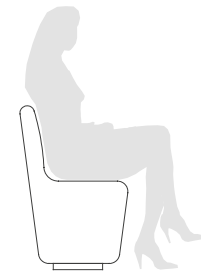

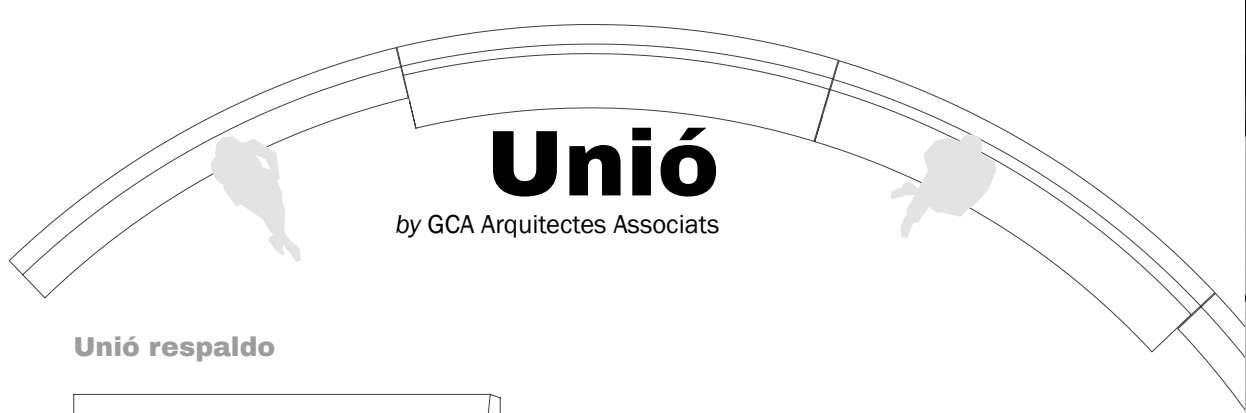

Unió respaldo



Unió asiento

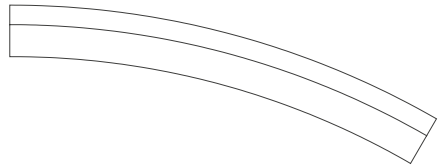
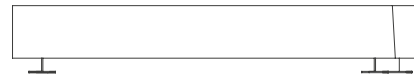

322 cm

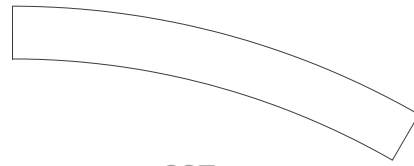

307 cm





Gandhi C

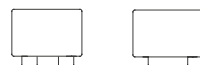

Gandhi B



210 cm

Gandhi Combi | 270 L

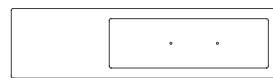
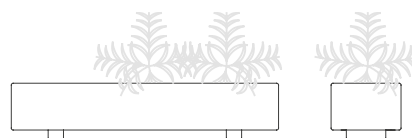

210 cm

Gandhi



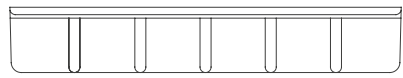
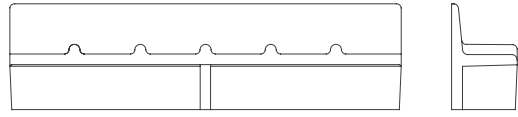

310 cm

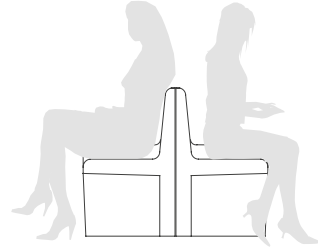

Nú

by Fante&Fabrè

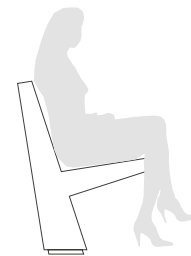

K-3

by Pedro Barragán, arquitecto



Guipúzcoa

by Pedro Barragán, arquitecto

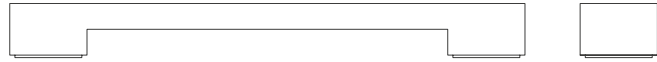

400 cm



MDT

by Ventura Valcarce

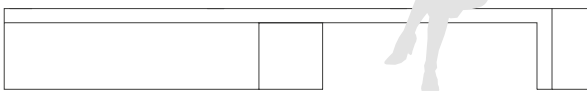

MDT non plus

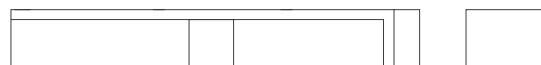

320 cm

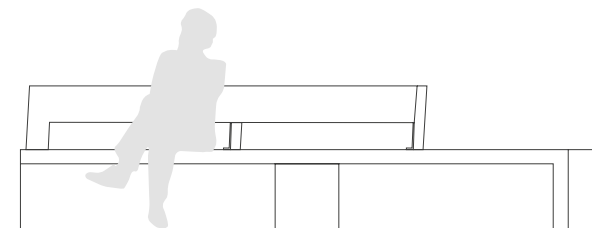

MDT plus

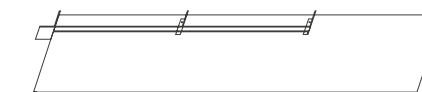
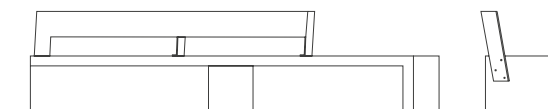

320 cm

Sol



Sol 100
Sol 140
Sol 180

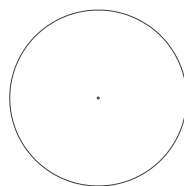

Ø 100 | 140 | 180 cm



Modulblock

by F8 Architectura

Modulblock

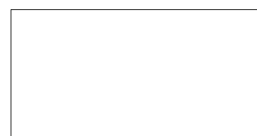

100

200 cm



Bécquer

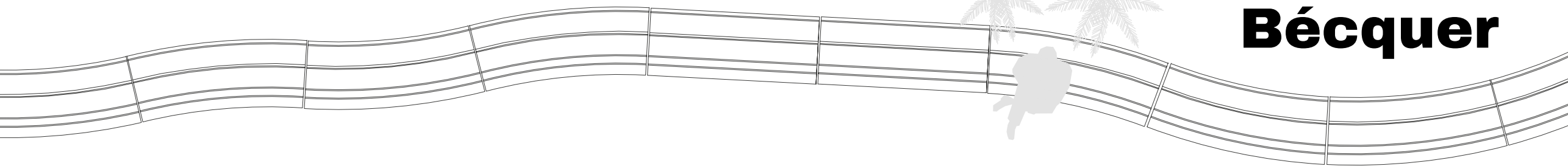

Recta, curva a la derecha, recta, curva a la izquierda, modula el espacio a tu gusto.

Straight, turn to the right, straight, turn to the left; shape space to suit you.

Recta, revolt a la dreta, recta, revolt a l'esquerra, modula l'espai al teu gust.

Tout droit, courbe à droite, tout droit, courbe à gauche, modulez l'espace à votre goût.

Bécquer recto



150 cm

Bécquer cóncavo 4.7 | 14.7



Bécquer convexo 4.7 | 14.7



Bécquer A

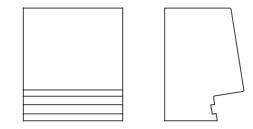

75 cm

Bécquer A1

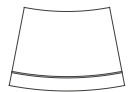
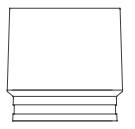

87 cm





Sentarse con los árboles

by Carlos Martín, arquitecto

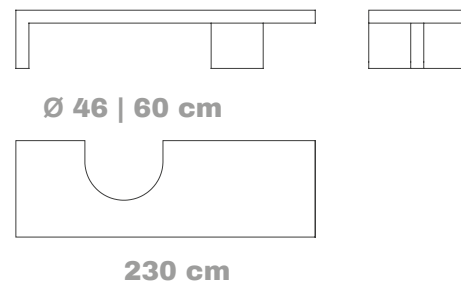
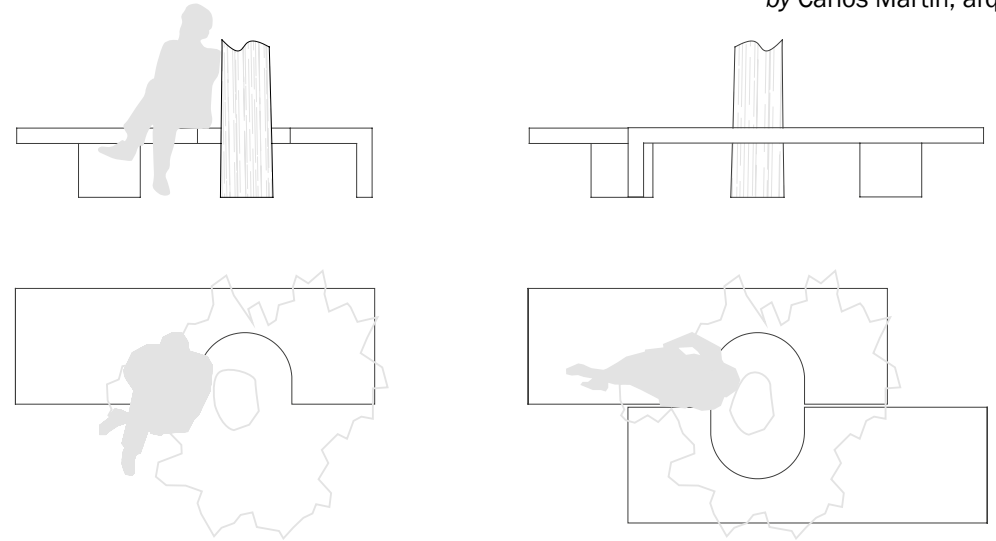

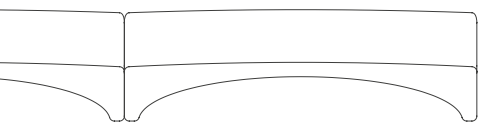

Ponte

by losdíz

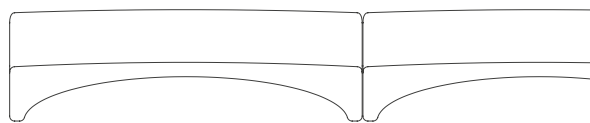

XIII
PREMIOS
AEPD



Ponte C

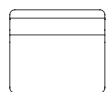
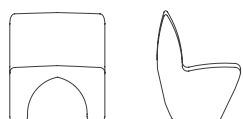

Ponte B

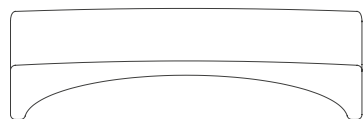

270 cm



Dynamic

Dynamic Q 50



50 cm

Dynamic T 50



50 cm

Dynamic TR 50



50 cm

Dynamic serp



50 cm

Dynamic I 100



100 cm

Dynamic I 150



150 cm

Dynamic I 200



200 cm

Dynamic I 240



240 cm

Dynamic I 260



260 cm

Dynamic Q 30



30 cm



Dynamic Q 100



100 cm

Dynamic T 100

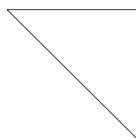

100 cm

Dynamic XL 300

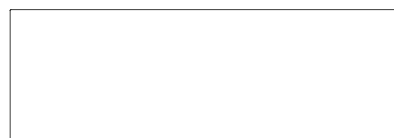

300 cm

Dynamic XL 400



400 cm

● Ver - Consultar papeleras Dynamic, p. 164
See - Consult Dynamic litter bins, p. 164

● Ver - Consultar accesorios, p. 216
See - Consult accessories, p. 216



Dynamic Q 100, Dynamic T 100, Dynamic XL 300 + Plus 1

Bus

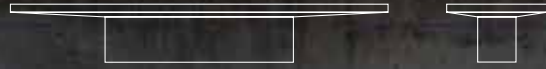

300 cm

80



A wide, paved promenade runs along a marina. On the left, several white sailboats are docked at a pier. The promenade is lined with young trees planted in dark grey, rectangular planters. The trees are supported by wooden stakes. In the background, there is a modern building with a glass facade and a blue pedestrian crossing sign. The sky is clear and blue.

jardineras
jardineres
planters
jardinières

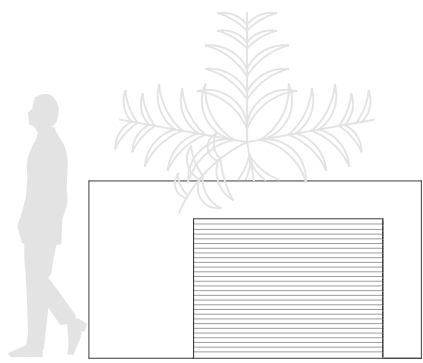

Tanit

by Ton Riera

Jardineras en diferentes formatos que por sus líneas sobrias y elegantes encajan en cualquier ambiente. El modelo Tanit L, es actualmente, la jardinera de mayor capacidad del mercado.

Planters in different formats with simple, elegant lines that allow them to blend seamlessly into any setting. The Tanit L is the largest-capacity planter on the market today.

Jardineras en diferents formats que per les seves línies sòbries i elegants s'integren en qualsevol ambient. El model Tanit L, és actualment, la jardinera amb més capacitat del mercat.

Jardinières de différentes tailles dont les lignes sobres et élégantes s'intègrent à tous les environnements. Le modèle Tanit L est actuellement la jardinière avec la plus grande capacité sur le marché.

Tanit S | 140x42x60(h) cm | 145 L

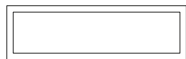

Tanit SP	 100x100x90(h) cm	 620 L
Tanit SM	 120x120x80(h) cm	 620 L
Tanit M	 150x150x80(h) cm	 1.040 L
Tanit L 60	 190x190x60(h) cm	 1.100 L
Tanit L 80	 190x190x80(h) cm	 1.510 L
Tanit L 115	 190x190x115(h) cm	 2.315 L

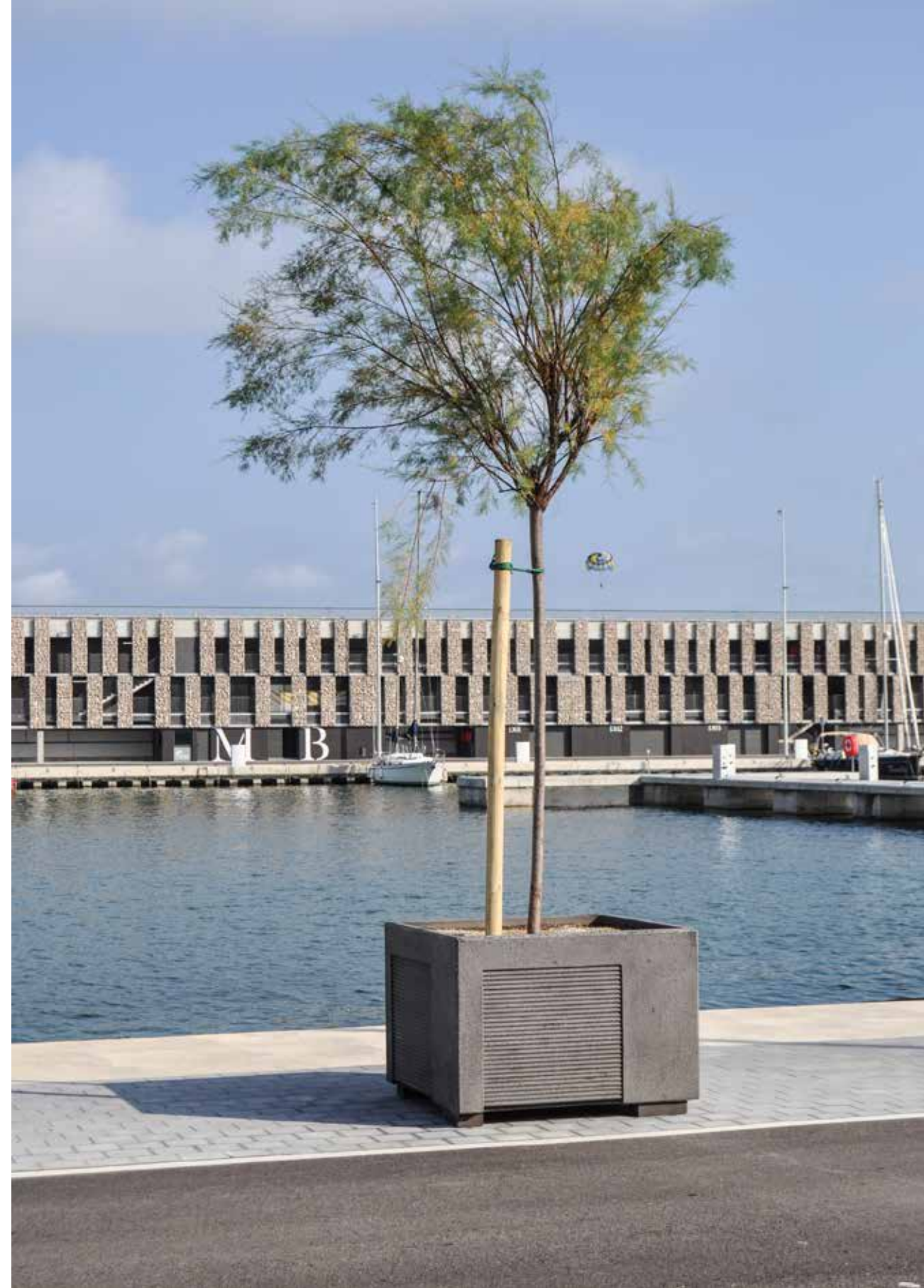
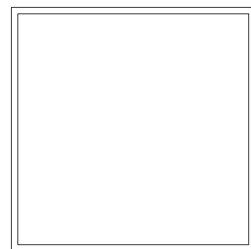
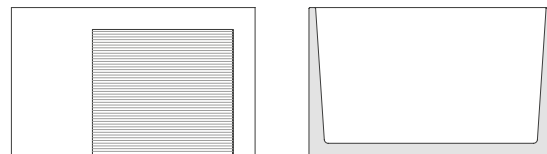

Cantorodado

by Stimulo

Modeladas sin aristas como si la misma naturaleza las hubiera erosionado.

Rounded design, as if eroded by nature itself.

Modelades sense arestes com si la mateixa natura les hagués erosionat.

Modelée sans bords comme si elle avait été érodée par la nature elle-même.

Cantorodado 100 | 146 L

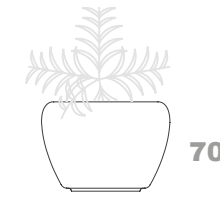

70

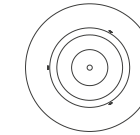

Ø 100 cm

Cantorodado 200 | 742 L

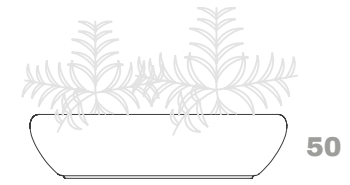

50

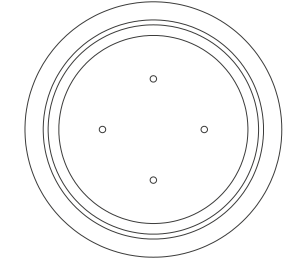

Ø 200 cm





Fuat

by Ton Riera

Hex

Hex 175 A | 580 L

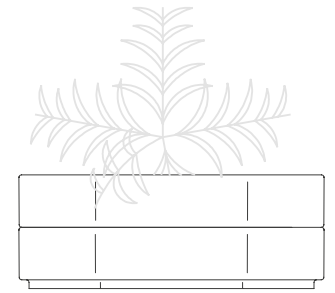
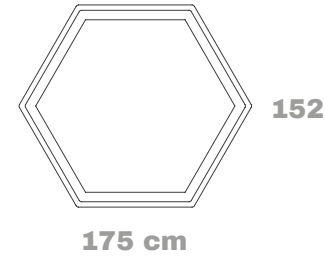
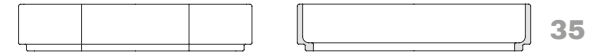

Hex 175 Base | 520 L

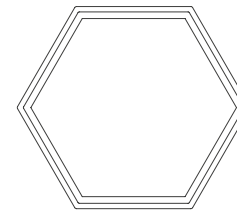

Fuat R 60 | 150x43x60(h) cm | 250 L
 Fuat R 80 | 150x52x80(h) cm | 400 L
 Fuat S 85 | 150x80x80(h) cm | 600 L

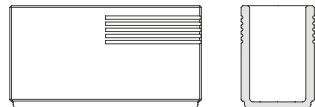

Fuat R 60 P | 150x43x69(h) cm | 250 L
 Fuat R 80 P | 150x52x89(h) cm | 400 L
 Fuat S 85 P | 150x80x89(h) cm | 600 L

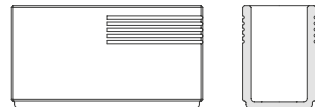

Fuat Q 60 | 162x162x60(h) cm | 1.150 L
 Fuat Q 80 | 162x162x80(h) cm | 1.570 L

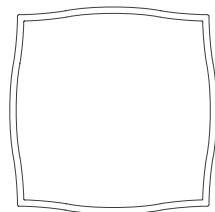
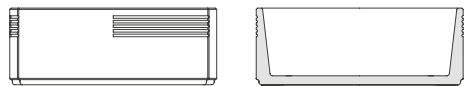

Fuat Q 60 P | 162x162x69(h) cm | 1.150 L
 Fuat Q 80 P | 162x162x89(h) cm | 1.570 L

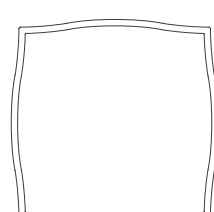
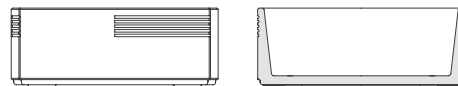



Granpot

Una jardinera de forma clásica que ha crecido al extremo.

A classic flower pot that has grown to the extreme.

Una jardinera de forma clàssica que ha crescut a l'extrem.

Une jardinière classique poussée à l'extrême.

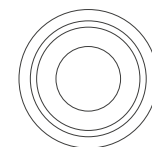
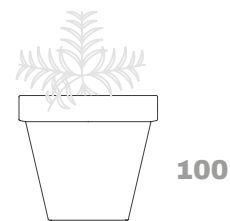

Ø 110 cm
390 L



Malva

Jardineras minimalistas que destacarán en cualquier espacio por su simplicidad estructural.

Minimalist planters will stand out in any space for their structural simplicity.

Jardineras minimalistes que destacaran a qualsevol espai per la seva simplicitat estructural.

Des jardinières minimalistes remarquables dans n'importe quel espace par leur simplicité structurelle.



Carrer Santa Maria, Preixana.

Malva CO45 | 39 L



Ø 45 cm

Malva CO50 | 59 L



Ø 50 cm

Malva CO60 | 105 L



Ø 60 cm

Malva CO80 | 195 L

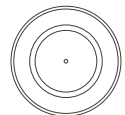

Ø 80 cm

Malva CO4080 | 140 L

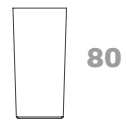

Ø 40 cm

Malva CO50110 | 150 L

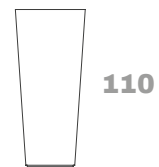

Ø 50 cm

Malva PI6025 | 82 L

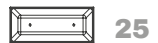
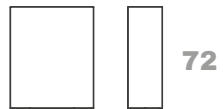

60 cm

Malva PI8040 | 93 L



80 cm

Malva PI9840 | 121 L

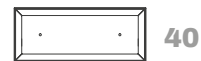

98 cm

Malva PI40 | 48 L
Malva PI4040 | 46 L
Malva PI50 | 96 L

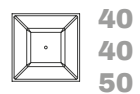
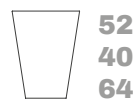

40 | 40 | 50 cm

Malva PI90 | 102 L

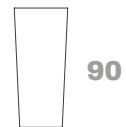

40 cm

Malva PI10050 | 407 L

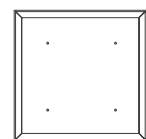

100 cm



Malva CO60, Malva PI90

Uve



33

33/4 | Ø102x29(h) cm | 103 L
33/5 | Ø119x47(h) cm | 262 L

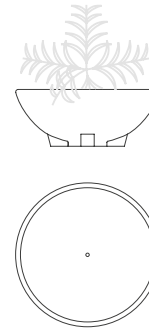

34

34/3 | Ø67x48(h) cm | 83 L
34/4 | Ø94x64(h) cm | 192 L

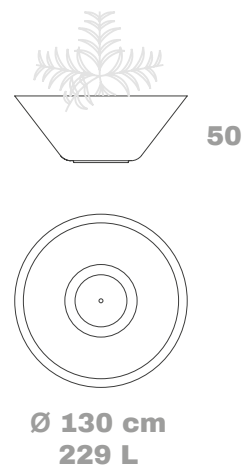
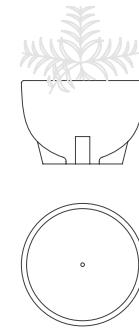

69

- 69/1 | Ø90x37(h) cm | 167 L
- 69/2 | Ø90x52(h) cm | 228 L
- 69/3 | Ø90x63(h) cm | 271 L
- 69/4 | Ø110x90(h) cm | 485 L
- 69/5 | Ø60x70(h) cm | 110 L

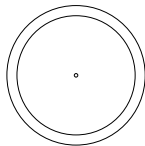
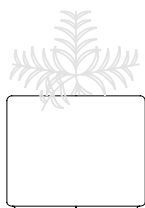

78

- 78/1 | Ø88x38(h) cm | 104 L
- 78/2 | Ø88x50(h) cm | 145 L
- 78/3 | Ø88x63(h) cm | 186 L

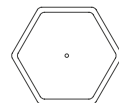
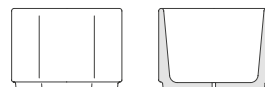

- 78/4 | Ø88x38(h) cm | 104 L

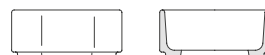

344N - 349N

- 344N | 73x34x43(h) cm | 58 L
- 345N | 74x44x45(h) cm | 75 L
- 346N | 100x34x43(h) cm | 95 L
- 347N | 100x60x64(h) cm | 250 L
- 348N | 120x60x64(h) cm | 432 L
- 349N | 100x60x93(h) cm | 345 L

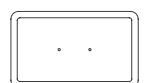
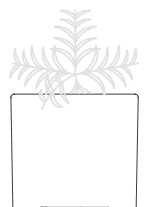

143

- 143/1 | 60x60x33(h) cm | 73 L
- 143/2 | 60x60x46(h) cm | 105 L
- 143/3 | 60x60x58(h) cm | 140 L
- 143/4 | 90x90x80(h) cm | 420 L
- 143/5 | 120x120x80(h) cm | 740 L

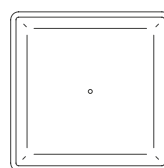
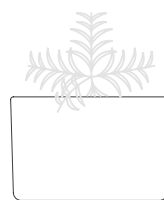

Ese

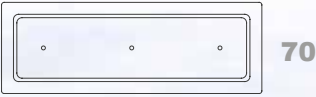
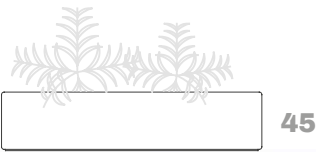

200 cm
325 L

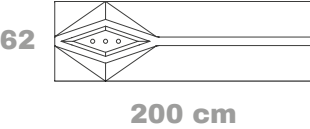
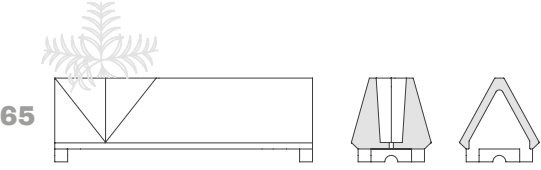



Espace

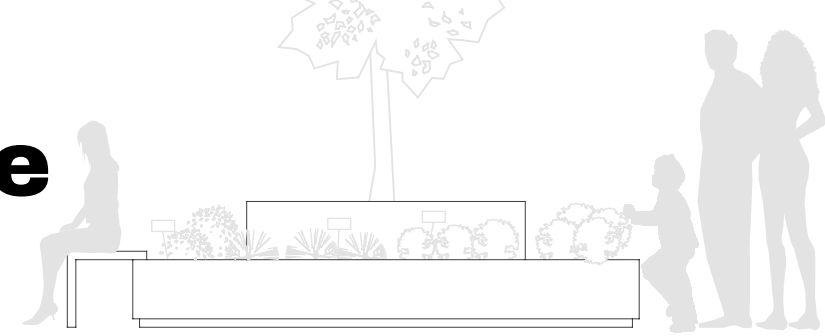

Espace C | 1.690 L

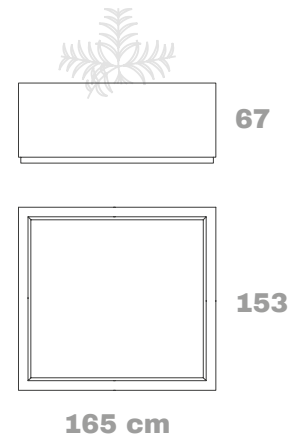

Espace G | 3.360 L

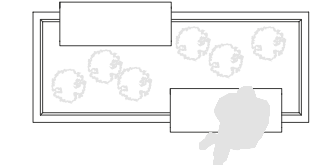
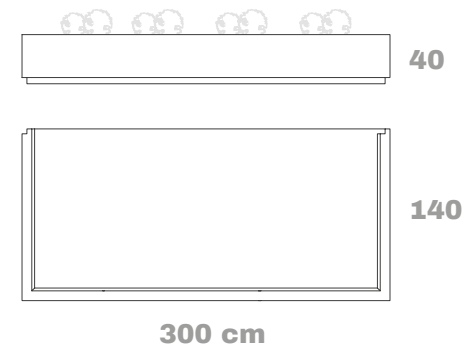

Espace B

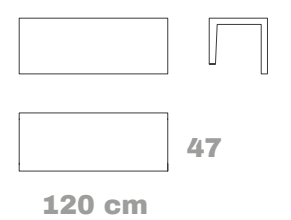

Espace R | 1.440 L

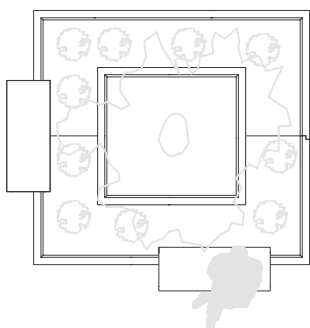
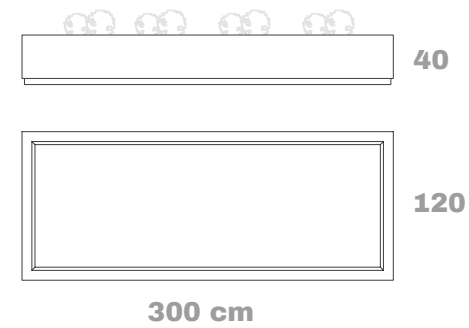

Espace, huerto urbano | urban garden





recogida de residuos
recollida de residus
waste collection
collecte de déchets



Fory

by Estudi Ribaudí

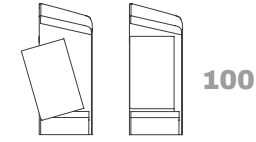

100



40 cm | 45 L

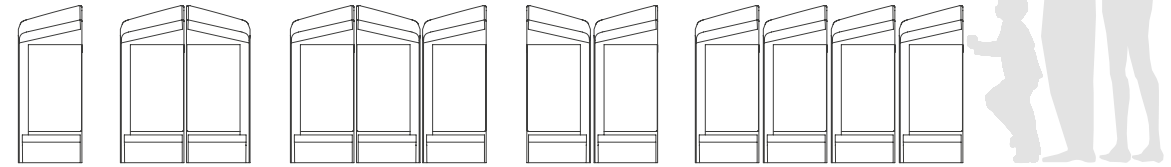

James Bond

James | 120 L



105



40 cm

Bond
cenicero | ashtray



90



40 cm





377N

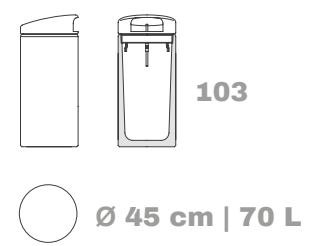

375N - 378N

375N | 70 L

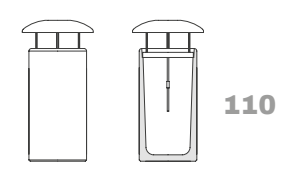

378N | 120 L

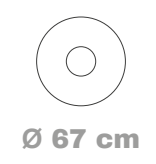
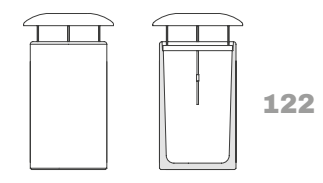

PA376B

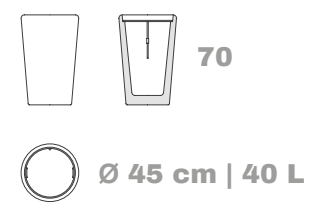



374N plus

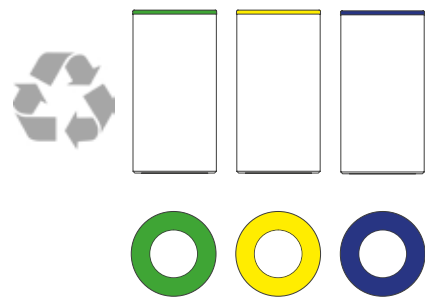
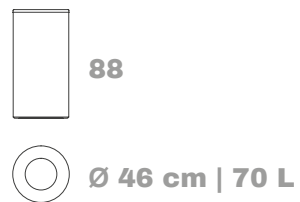

374N - 379N

374N | 70 L

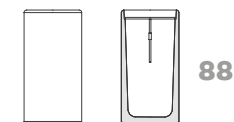

379N | 120 L

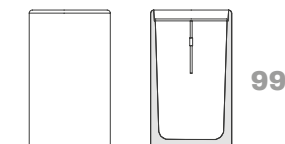

376

cenicero | ashtray

376A

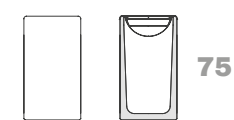

376N

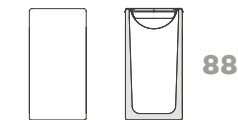

376B

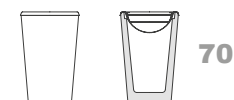

Versatil

Versatil | 65 L

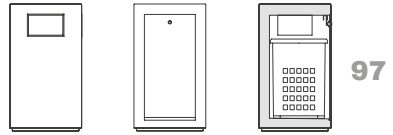

55 cm

Versatil plus | 65 L

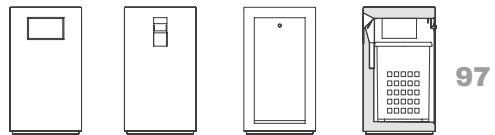

55 cm



Versatil plus



Dynamic

Dynamic P

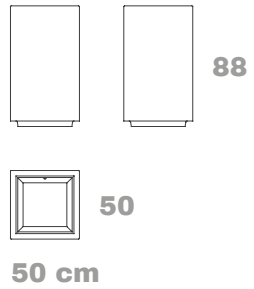

Dynamic P

Dynamic PG

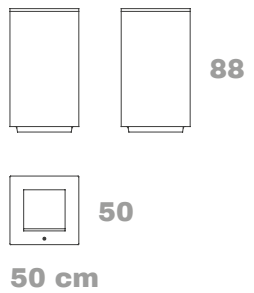

Dynamic PG



Dynamic PB

Dynamic PB

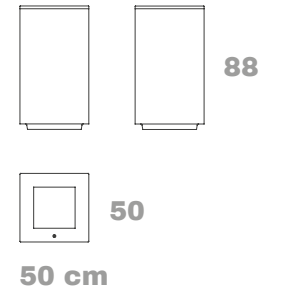

● Ver - Consultar
bancos Dynamic, p. 126
See - Consult
Dynamic benches, p. 126

Dynamic P4E

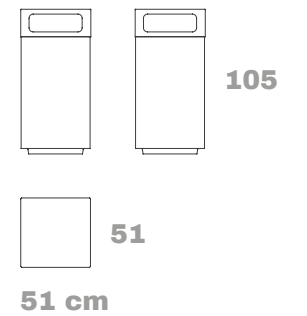

Dynamic P4E

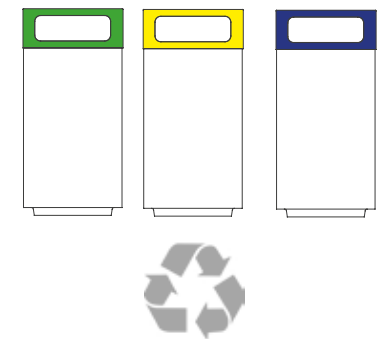



límites
límits
bollards
limites

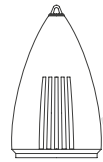
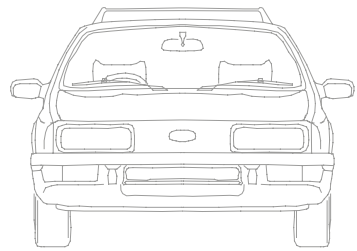

Rodas

by Ton Riera

Rodas



110



Ø 68 cm

Rodas RF (reflectant)

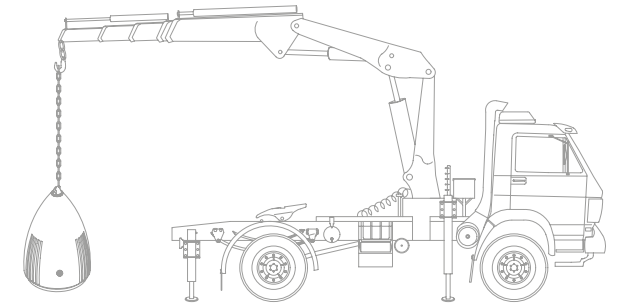



Balisa JM by Jordi Miralles, Jordi Miró

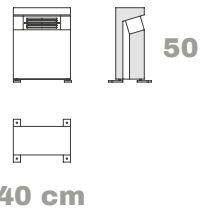

Ursus by Xavier Bruçet

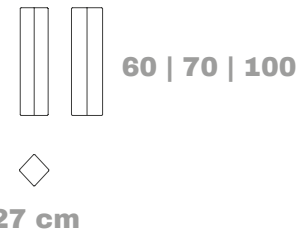

Pausita by Oriol Guimerà

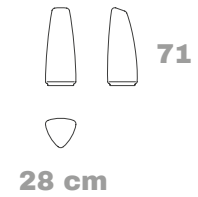

Cilo by Ernest Perera

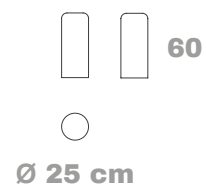

Garcilaso

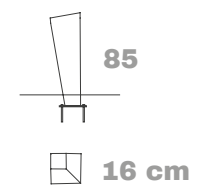



128 ... 138N

128 | 30x30x30(h) cm
 129 | 35x35x35(h) cm
 130 | 40x40x40(h) cm
 131 | 45x45x45(h) cm

136N | Ø 45x26(h) cm
 137N | Ø 45x38(h) cm
 138N | Ø 45x47(h) cm

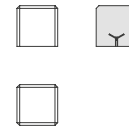

120 | Ø 30 cm
 121 | Ø 35 cm
 122 | Ø 40 cm
 123 | Ø 45 cm
 124 | Ø 55 cm

121B | Ø 35x18(h) cm
 122B | Ø 40x20(h) cm
 123B | Ø 45x23(h) cm
 124B | Ø 55x28(h) cm

123C | Ø 45x45(h) cm

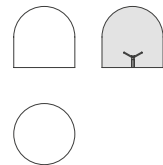
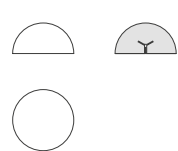
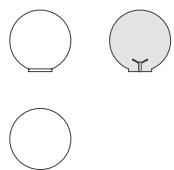

120 ... 124B

123E

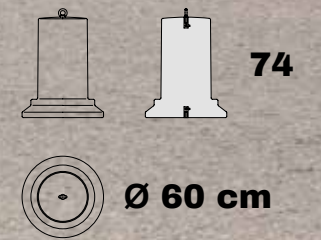
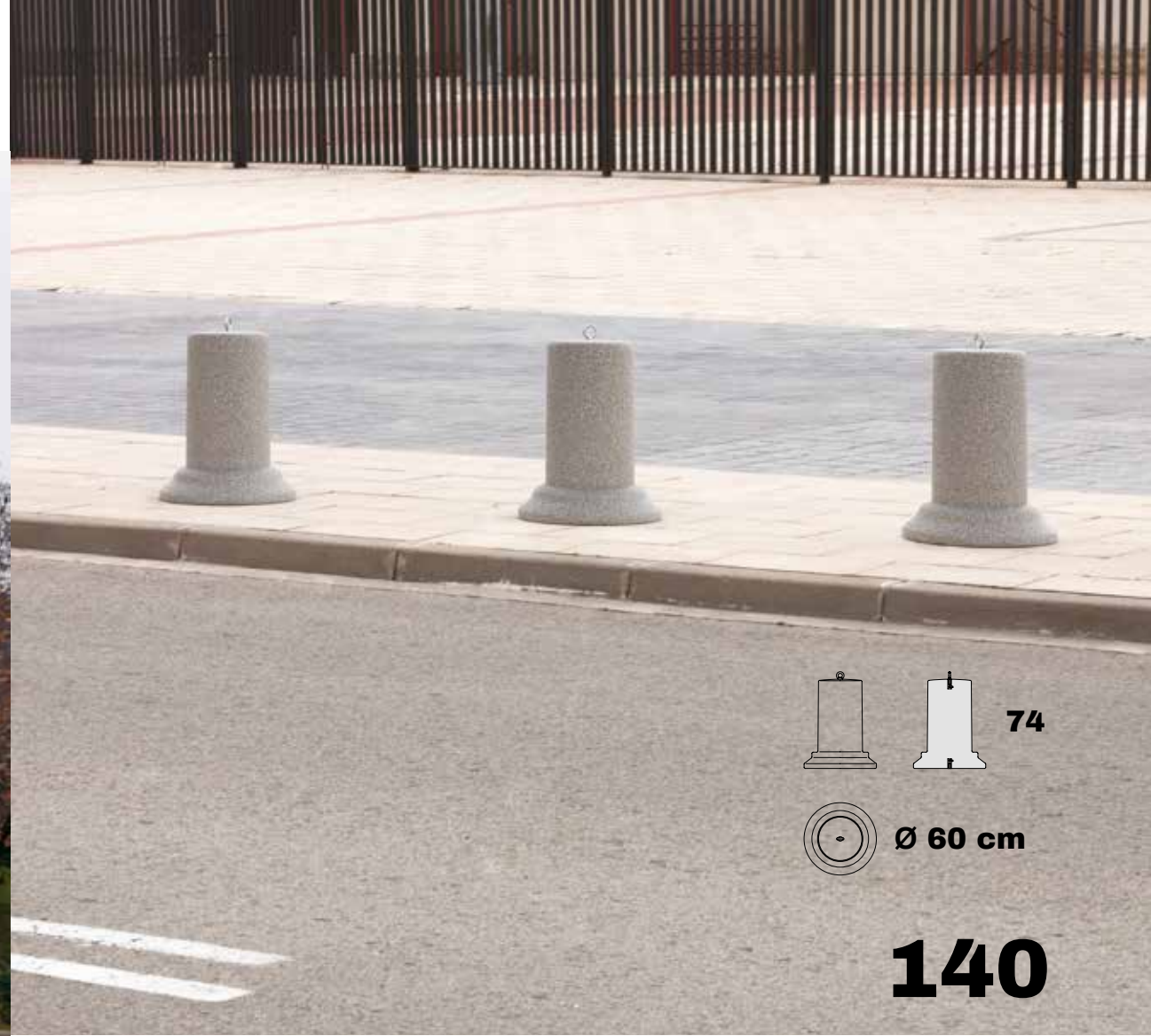
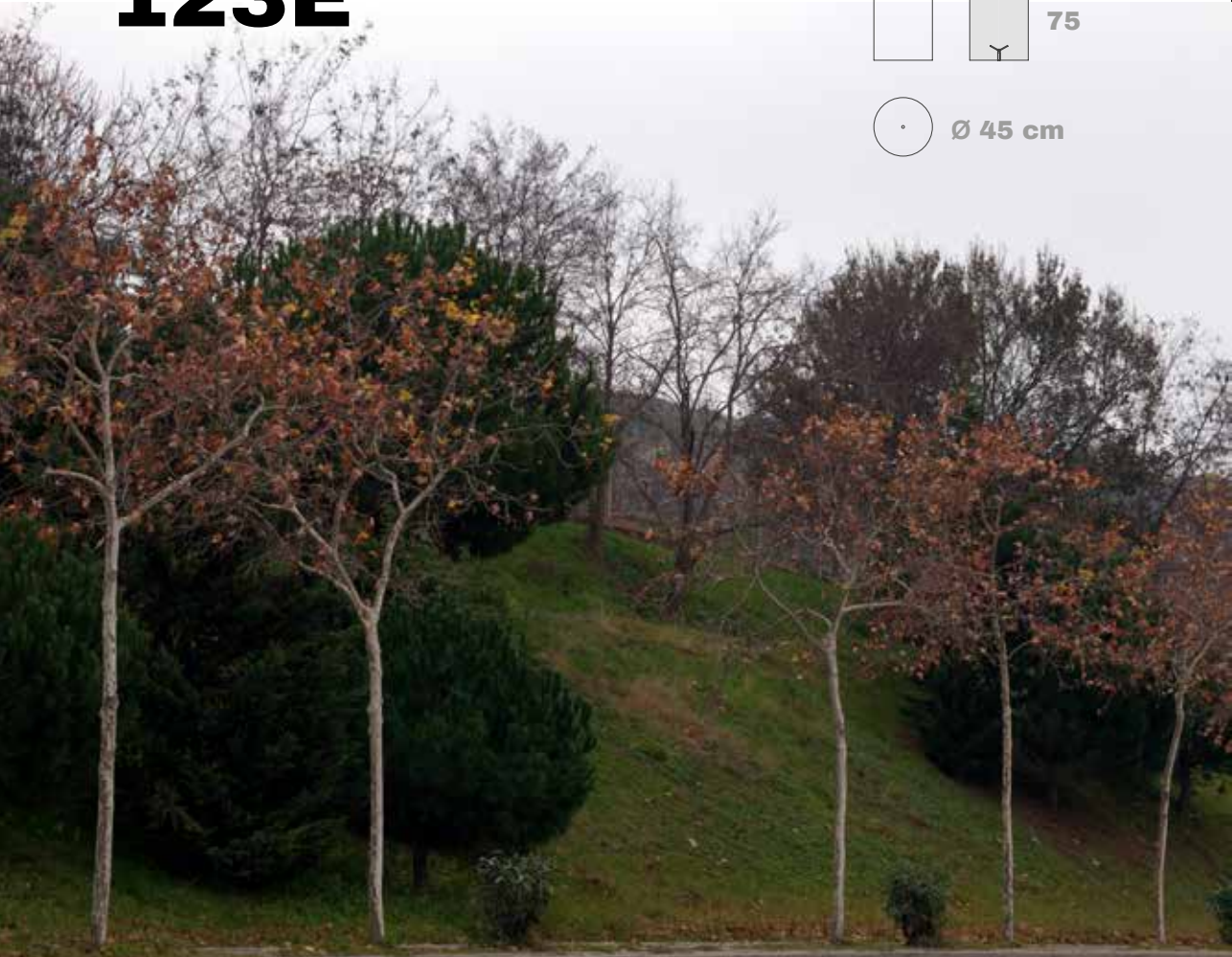
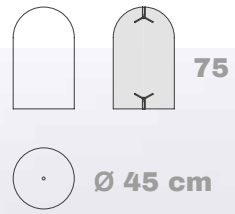

140

- 132 | 25x25x37(h) cm
- 133 | 28x28x60(h) cm
- 134 | 30x30x74(h) cm

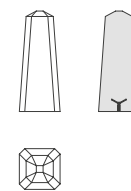

135

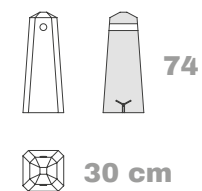

135/1

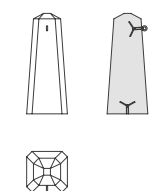

135/2

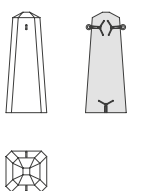

132 ... 135/2



picnic
picnic
picnic
pique-nique



Picnic S194

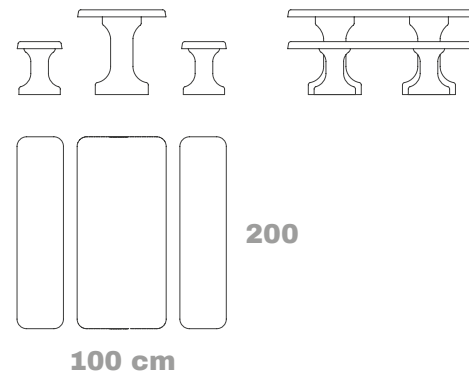

**Picnic S200
Picnic S201**

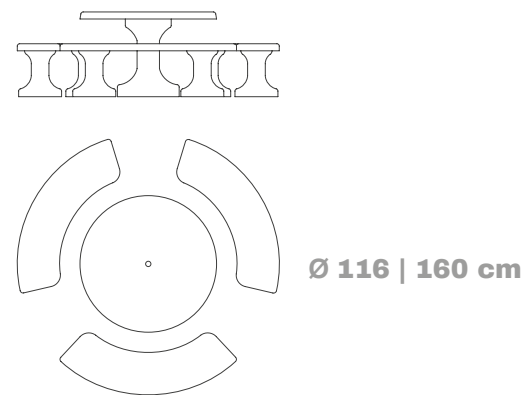

Picnic

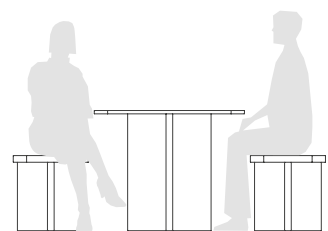

Buseu

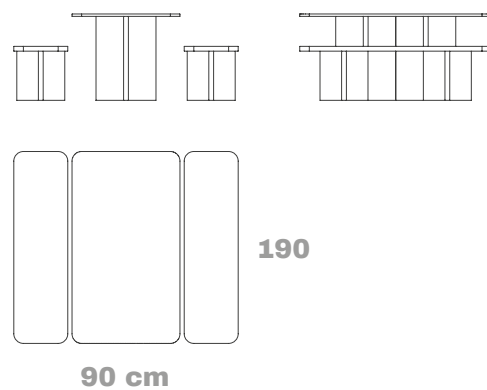

Targa

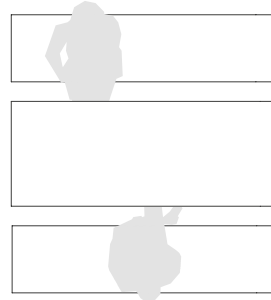

Targa T 77

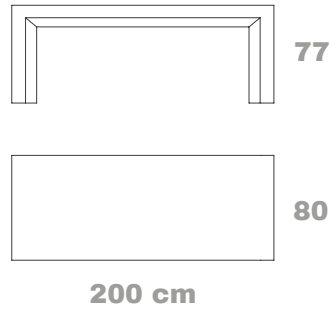

Targa B 50

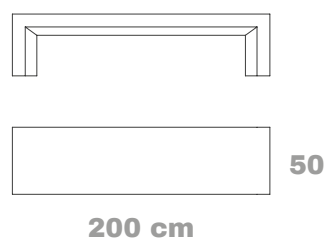

Portic

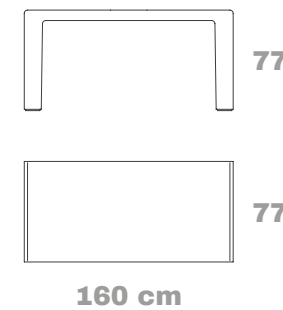

Tetris I 150

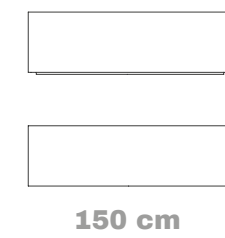

Tetris Q

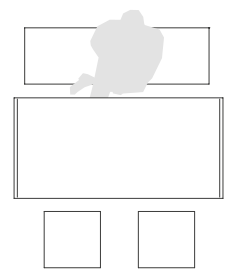
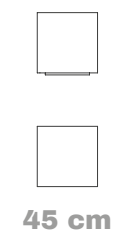

Portic + Tetris

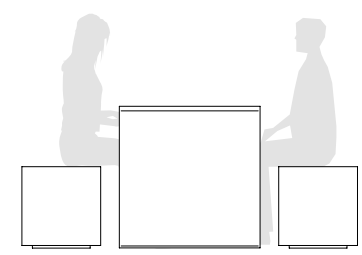

Multi bench

by Hiroshi Tsunoda

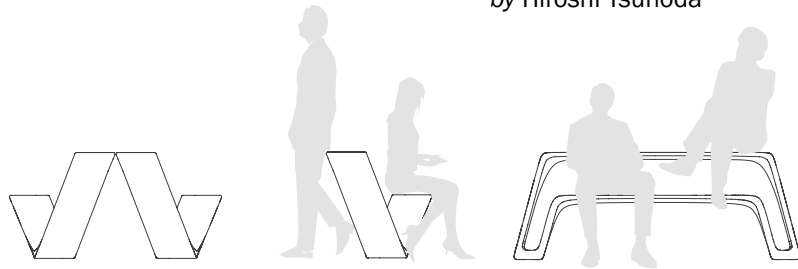

El término sentarse pierde formalidad en este banco. Un elemento diseñado sin estereotipos para utilizarse de diferentes modos.

El terme asseure's perd formalitat en aquest banc. Un element dissenyat sense estereotips per utilitzar-se de diferents maneres.

The term sit down loses its formality with this bench. An element designed free of stereotypes, to be used in different ways.

Le verbe s'asseoir perd toute formalité sur ce banc. Un élément conçu sans stéréotypes, à utiliser de différentes manières.

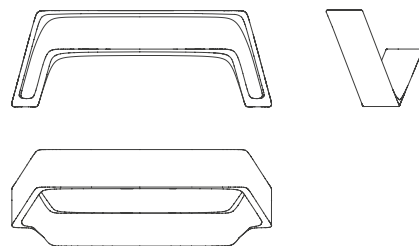

200 cm





Simplex

by SUMA Arquitectes

Simplex <8

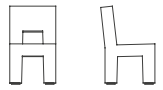

Simplex

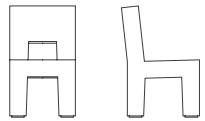

Triplex

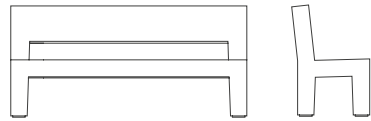

180 cm

Lex



180 cm



Complex A
Complex B



52 | 65



100

100 cm

Complex C
Complex D



65 | 67



92 | 95

185 | 232 cm

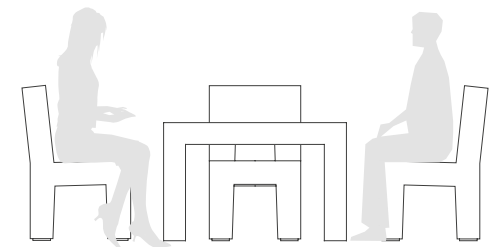

Complex

by SUMA Arquitectes



pavimentos
paviments
pavements
revêtements

Ripple

by In-Tenta design + Daniela Seminara

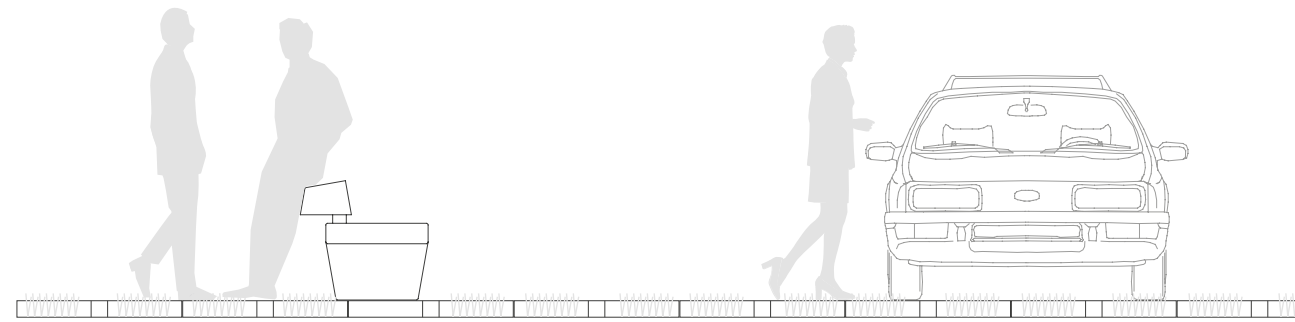
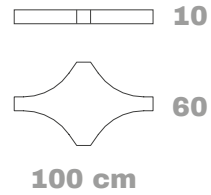

Pavimento verde que se inspira en las formas del desierto, cuyo diseño proporciona una sinuosa 'retícula' de hormigón y hierba para zonas de tráfico peatonal y vehículos ligeros.

Paviment verd que s'inspira en les formes del desert proporcionant una sinuosa 'retícula' de formigó i gespa per a zones de trànsit peatonal i vehicles lleugers.

Green pavement inspired by the shapes of the desert. Its design creates a concrete and grass lattice for areas with pedestrian and light vehicle traffic.

Revêtement de sol vert inspiré par les formes du désert, dont la conception offre un 'treillage' sinuose de béton et d'herbe pour les zones de circulation des piétons et des véhicules légers.

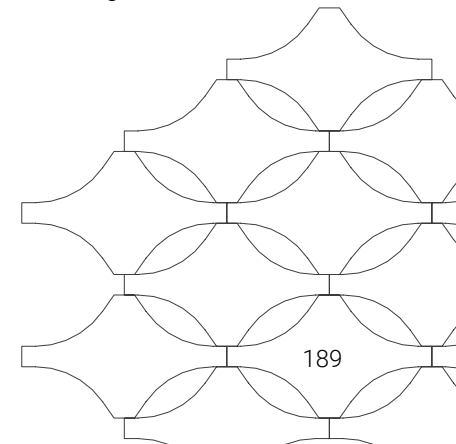



Maira

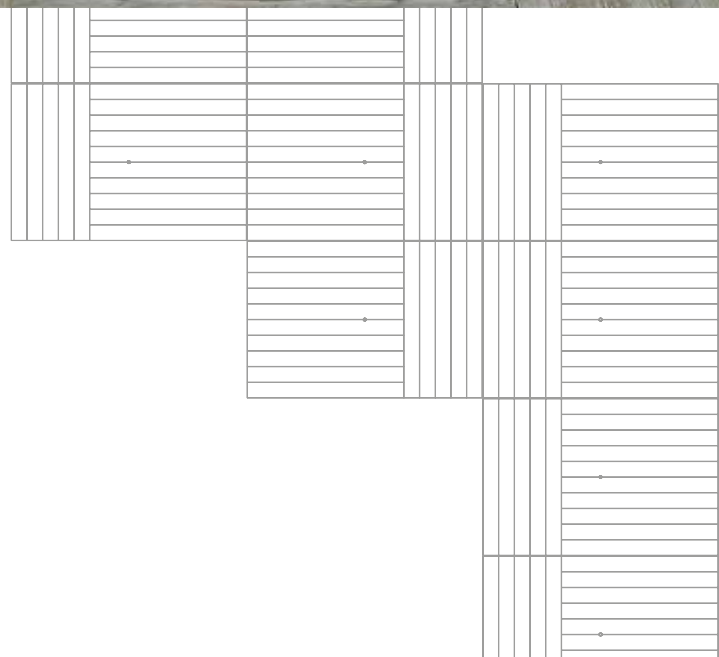
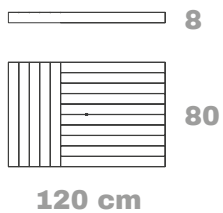

Hoop

by ACTAR Arquitectura

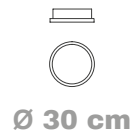

Luna 60

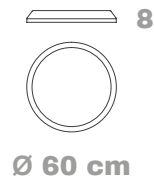

Toscana

by Arturo Frediani, arquitecto

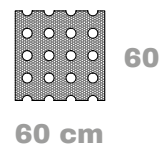



Via láctea

by Ernest Perera

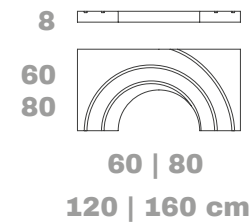

Tv

by Ernest Perera

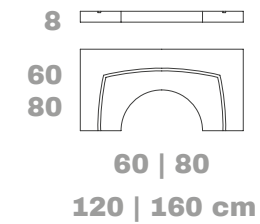

Cap i cua

by Juan Carlos Bolaños

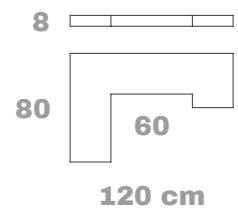

Mekano Q _ SUMA Arquitectes



Mekano Q

by SUMA Arquitectes

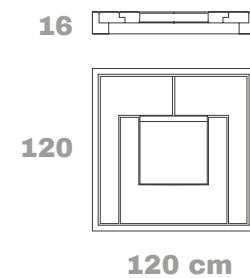

Hospital Quirón Madrid

Pavimento Gran Formato | *Large-format Pavement*

PROMOTOR: Hospital Quirón
ARQUITECTO: Albert Pineda, Pinearq, S.L.
EMPLAZAMIENTO: Madrid



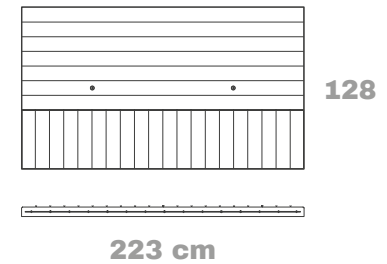
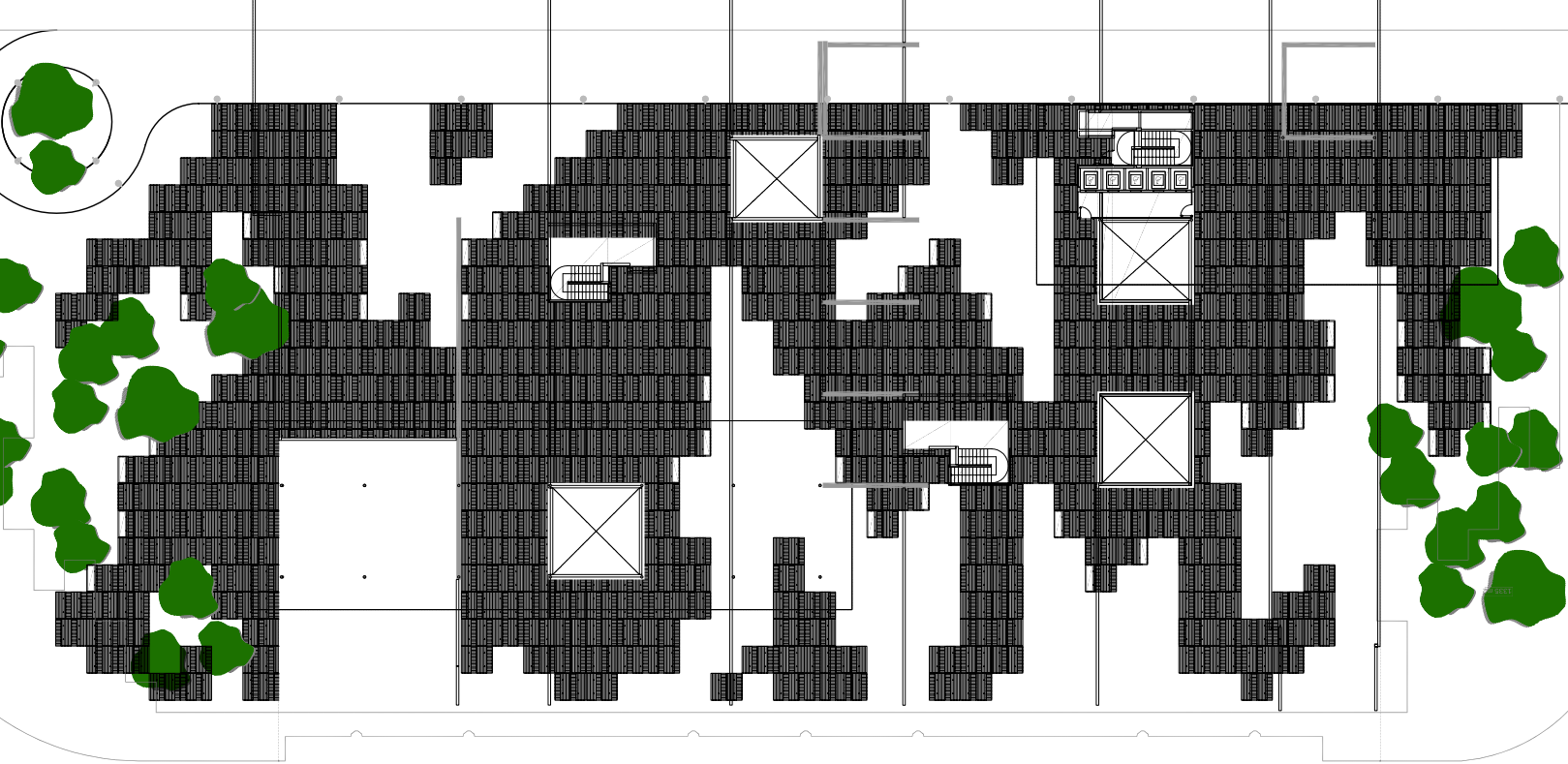

Hospital Quirón, Madrid.

Jardines Mercè Vilaret

Pavimento Gran Formato | *Large-format Pavement*

PROMOTOR: ProEixample

ARQUITECTO: Ana Sánchez Patús

EMPLAZAMIENTO: Barcelona





Jardines Mercè Vilaret, Barcelona.

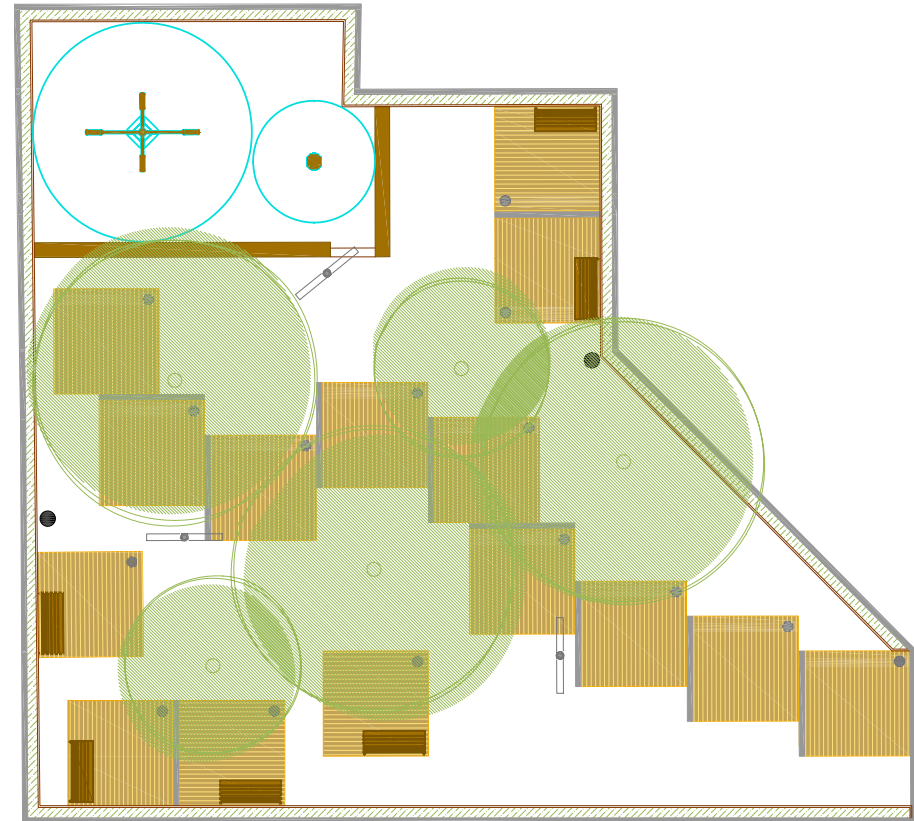
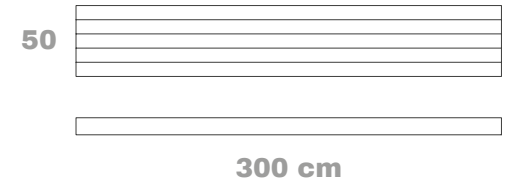

BCN Biomedical Research Park

Pavimento Gran Formato | *Large-format Pavement*

PROMOTOR: Ajuntament de Barcelona

ARQUITECTO: Brullet i Associats, S.L.

EMPLAZAMIENTO: Barcelona





BCN Biomedical Research Park, Barcelona.

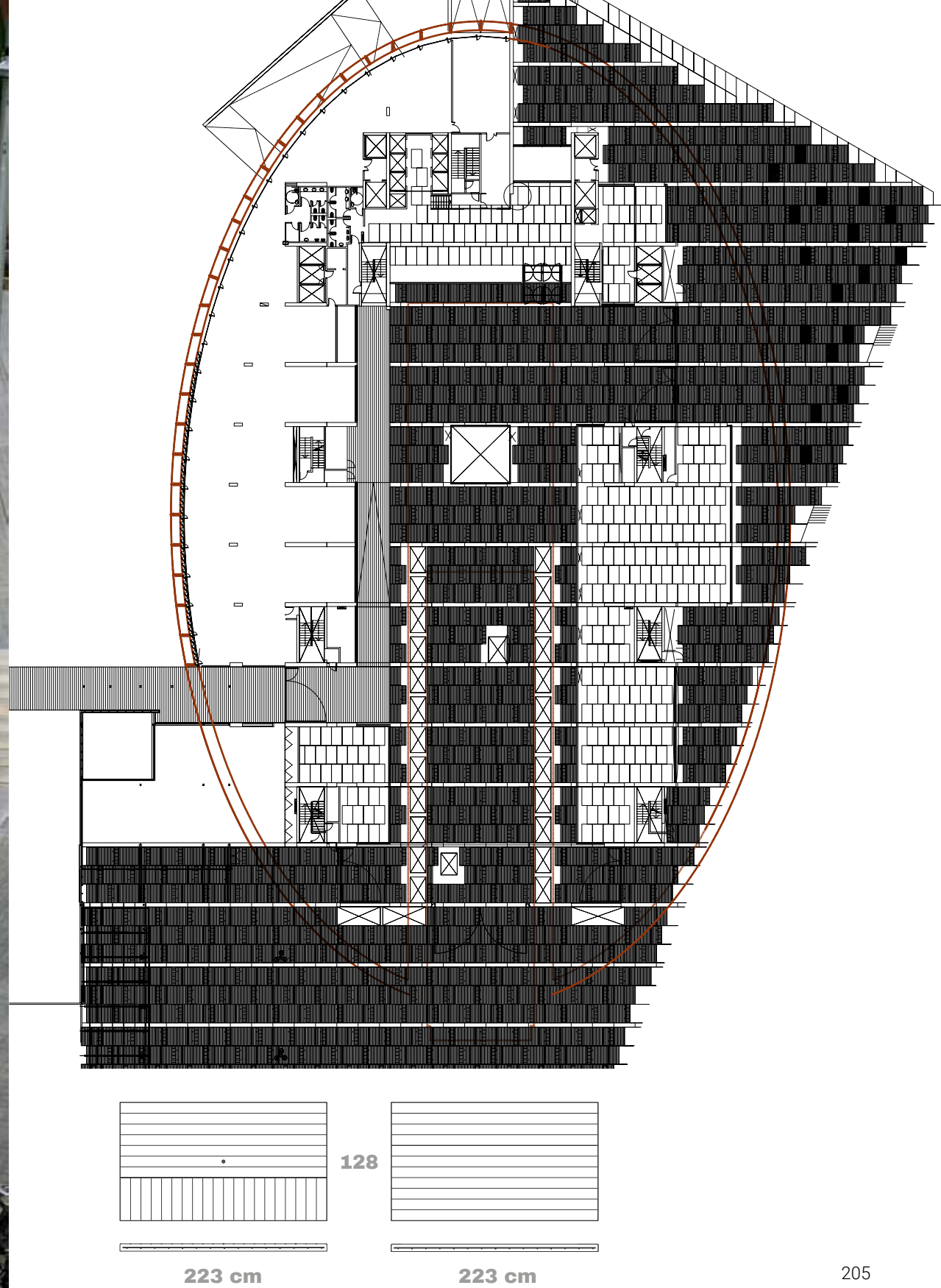



Garcilaso

Pavimento Gran Formato | *Large-format Pavement*

PROMOTOR: Bimsa

ARQUITECTO: Pedro Barragán, Miguel Payá

EMPLAZAMIENTO: Barcelona





Calle Garcilaso, Barcelona.

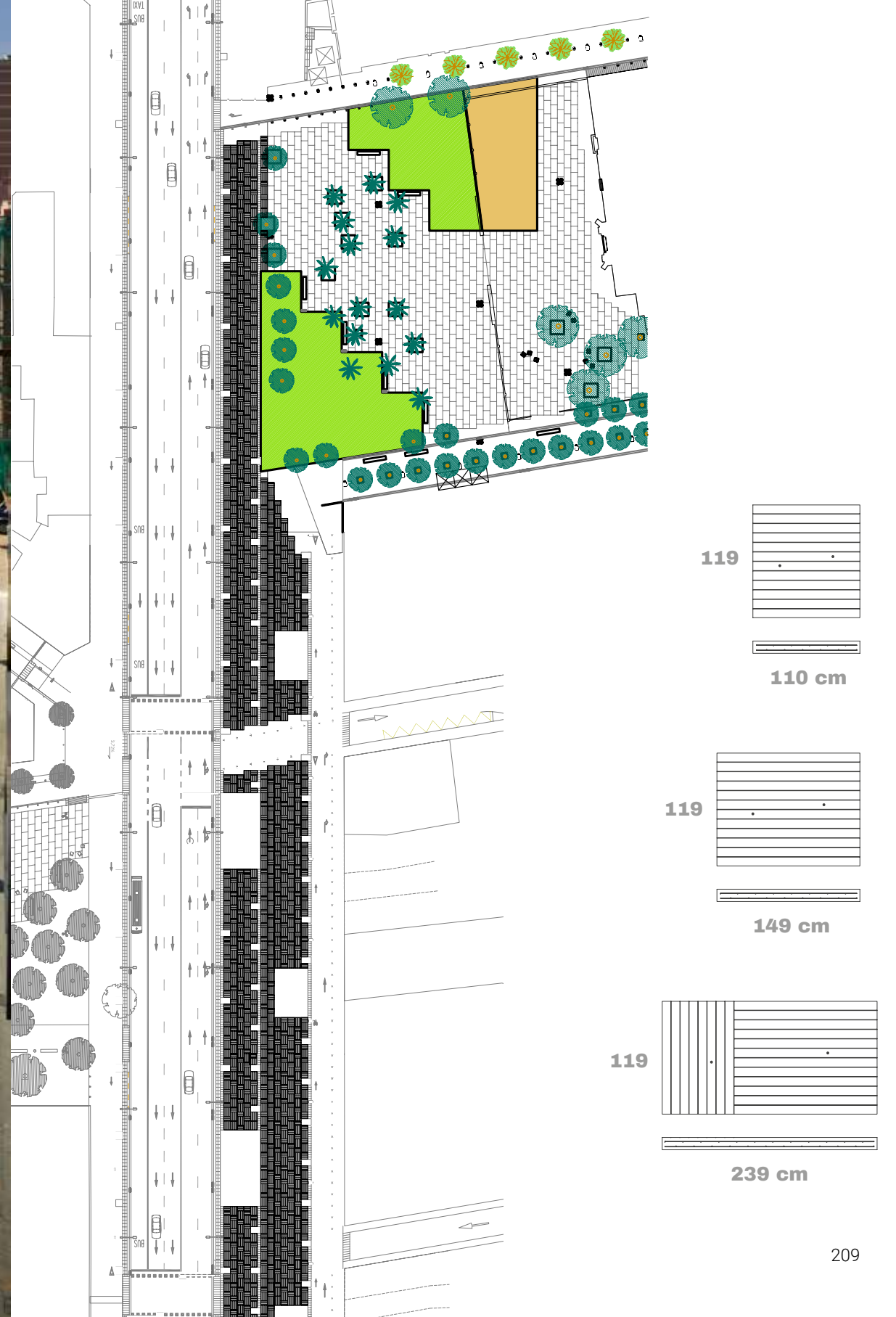

119

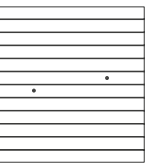

110 cm

119

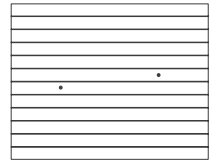

149 cm

119

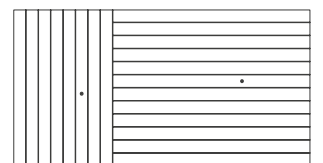

239 cm

miscelánea
miscelània
miscellaneous
divers



Pin

by CrousCalogero



90



34 cm

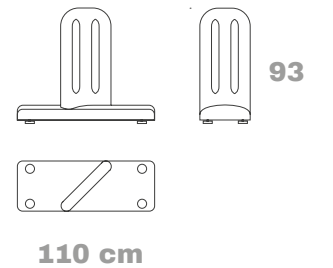

93

110 cm

Cyclo

by losdiez

Fontana

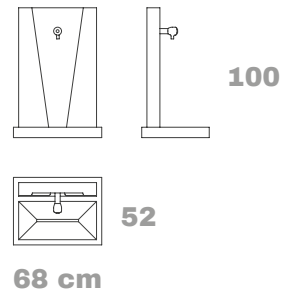

Limitot

by Ton Riera

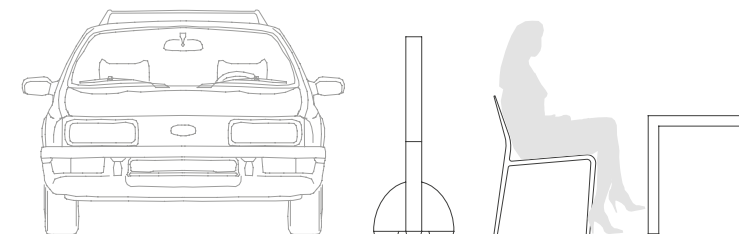
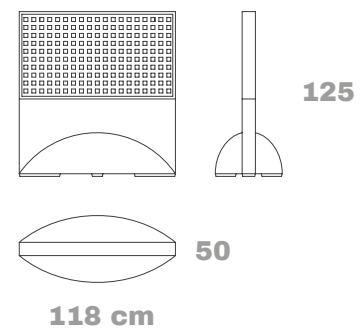

accessorios
accessoris
accessories
accessoires





Antiskate

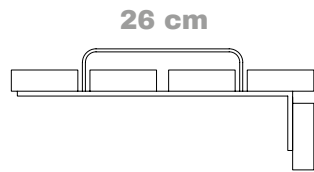
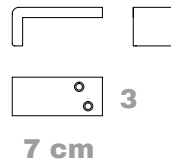

Antisleep



Plus



Plus 1

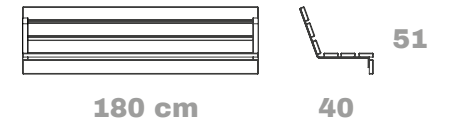

Plus 2

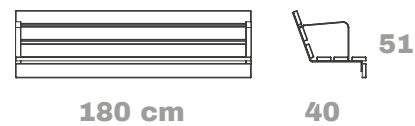

Plus 3

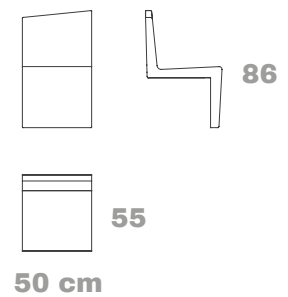

Plus 4

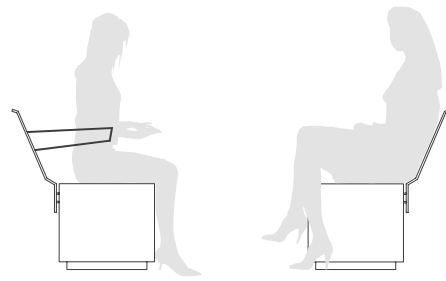

Plus 4 S



100 cm

Plus 4 D

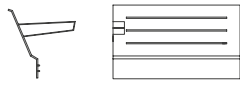

100 cm

Plus 4 E



100 cm

Plus 4 DE

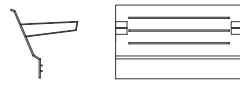

100 cm



Plus 5 D

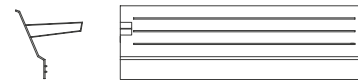

200 cm

Plus 5 E

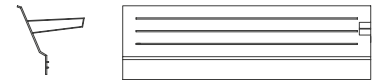

200 cm

Plus 5 S

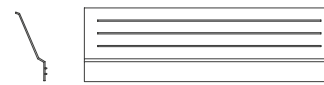

200 cm

Plus 5 DE

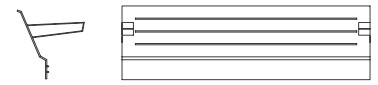

200 cm

Plus 5 C

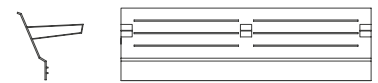

200 cm

Plus 5



colores | colors



colores opcionales | optional colors

Petra 1



colores | colors

Petra 2

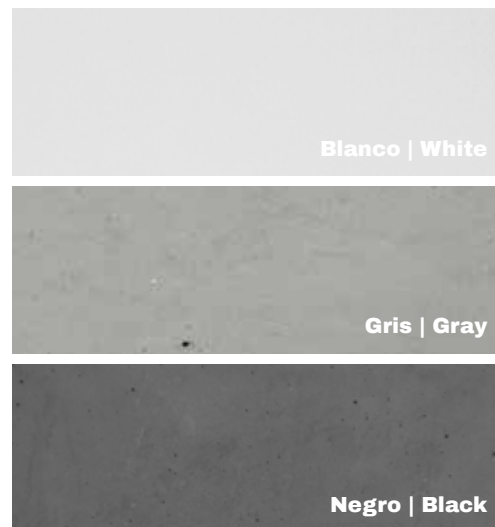

colores | colors

SMC (UHPC)

acabado liso + antigraffiti
smooth finish + antigraffiti

acabados de superficie

Solo disponibles en:
jardineras, recogida de residuos y límites

surface finishes

Available:
planters, waste collection and bollards

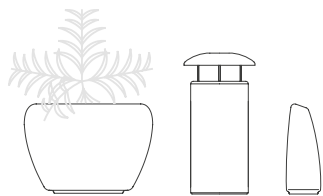
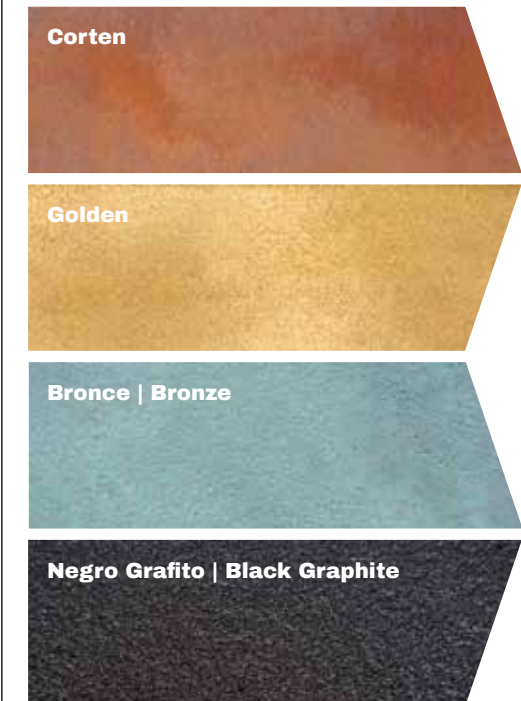

acabados de superficie

Solo disponibles en:
jardineras, recogida de residuos y límites

surface finishes

Available:
planters, waste collection and bollards



DESIGNERS

Nuestra Colección de Autor es fruto de las ideas de arquitectos y diseñadores, y nuestros más de treinta años de experiencia en el sector.

La nostra Col·lecció d'Autor és fruit de les idees d'arquitectes i dissenyadors, i la nostra experiència de més de 30 anys en el sector.

Our Signature Collection is result of the ideas of architects and designers, and our more than 30 years of experience in this field.

Notre Collection d'Auteur est le résultat des idées d'architectes et de designers et notre plus de 30 ans d'expérience dans le secteur.

ACTAR ARQUITECTURA
ALÒS IDEES
ARTURO FREDIANI, ARQUITECTO
BOW DESIGN
CARLOS MARTÍN, ARQUITECTO
CRISTINA NOGUER, JOAQUIM ROQUÉ, JOSEP MOTAS
CROUSCALOGERO
DEN STUDIO
EMBT / BENEDETTA TAGLIABUE
ERNEST PERERA
ESTUDI RIBAUDÍ
EWALD WINKELBAUER
FANTE&FABRÉ
FOREIGN OFFICE ARCHITECTS
F8 ARQUITECTURA
GCA ARQUITECTES ASSOCIATS
GUIDO MARSILLE
HIROSHI TSUNODA
IN-TENTA DESIGN + DANIELA SEMINARA
JESÚS ALFARO, ANA HURTADO
JOAN CINCA
JORDI MIRALLES
JORDI MIRÓ
JUAN CARLOS BOLAÑOS
KUTARQ STUDIO + YHY DESIGN
LA NOCHE DE LA IGUANA / KIKO SOLSONA
LOSDÍEZ
MIBA ARCHITECTS + SIO2
ORIOI GUIMERÀ
ORIOI PARDO
PEDRO BARRAGÁN, ARQUITECTO
ROGER ALBERO
STIMULO
SUMA ARQUITECTES
TON RIERA
VENTURA VALCARCE
XAVI FERRÚS
XAVIER BRUCET





magourban



magourban

Avinguda de Cervera, 19 · 25300 Tàrraga

Tel. +34 973 158 703

Fax +34 973 501 253

comercial@magourban.com

magourban.com